

# HX Series Recirculating Chiller TC-400 Controller

NESLAB Manual P/N U00244  
Rev. 07/03/97

## Installation, Operation, and Maintenance Manual



### **NESLAB online**

Product Service Information, Electronic Catalog,  
Applications Notes, MSDS Forms, e-mail.

**(603)427-2490**

Set modem to 8-N-1 protocol, 1200 - 14400 baud

Voice Info: (800) 4-NESLAB

Comments on this manual can be sent to:

**NESLAB@lifesciences.com**

or visit our Web page at:

**<http://www.neslabinc.com>**

# HX Series Recirculating Chiller Installation, Operation, and Maintenance Manual

## Table of Contents

<b>PREFACE</b>	
	Compliance ..... 5
	Unpacking ..... 5
	Warranty ..... 5
	After-sale Support ..... 5
<b>SECTION I</b>	
<b>Safety</b>	
	Warnings ..... 6
<b>SECTION II</b>	
<b>General Information</b>	
	Description ..... 7
	Specifications ..... 8
	Cooling Capacity ..... 9
	Pump Capacity ..... 10
<b>SECTION III</b>	
<b>Installation</b>	
	Site (Air-cooled Units) ..... 12
	Site (Water-cooled Units) ..... 14
	Electrical Requirements ..... 16
	Plumbing Requirements ..... 17
	Fluids ..... 19
	Water Quality Standards and Recommendations ..... 20
	Filling Requirements ..... 21
<b>SECTION IV</b>	
<b>Temperature Controller</b>	
	Controller Keypad ..... 22
	Status Indicators ..... 23
	Changing a Value ..... 25
	Controller Displays ..... 25
<b>SECTION V</b>	
<b>Operation</b>	
	Flow Control ..... 28
	Start Up ..... 28
	Pressure Gauge ..... 28
	Pressure Relief Valve ..... 29
	High Pressure Cutout ..... 29
	Pump Motor Overload Protector ..... 30

**SECTION VI  
Optional Features**

Automatic Refill Device ..... 31  
Heater Package ..... 32  
External Pressure Regulator ..... 34  
Remote Condenser ..... 35  
Nitrogen Purge ..... 35  
Particulate Filters ..... 35

**SECTION VII  
Maintenance**

Service Contracts ..... 36  
Condenser Cleaning ..... 36  
Algae ..... 36

**SECTION VIII  
Service**

Configuration ..... 37  
Reservoir Cleaning ..... 38  
Pump and Flow Switch Strainers ..... 39  
Pump Motor Lubrication ..... 41  
Phase Rotation ..... 41  
Suction Discharge Pressure and Speed Check ..... 42

**SECTION IX  
Troubleshooting**

Checklist ..... 43  
Service Assistance ..... 43

**SECTION X  
Diagrams**

Refrigeration Flow (HX-75 through HX-150) ..... 44  
Refrigeration Flow (HX-200 through HX-750) ..... 44  
Pump Flow (CP Pumps) ..... 45  
Pump Flow (PD and TU Pumps) ..... 45  
Dimensions ..... 46

**APPENDIX A**

**Standard Analog Interface**

**APPENDIX B**

**Programming Software**

**WARRANTY**

## Quick Start Procedures Air-Cooled Models

### Installation

Position the unit so the intake and discharge are not impeded. Inadequate ventilation will cause a reduction in cooling capacity and, in extreme cases, compressor failure.

Avoid excessively dusty areas and institute a periodic cleaning schedule. For proper operation, the unit needs to pull substantial amounts of air through a condenser. A build up of dust or debris on the fins of the condenser will lead to a loss of cooling capacity.

The unit will retain its full rated capacity in ambient temperatures up to approximately +24°C.

Ensure the voltage of the power source meets the specified voltage,  $\pm 10\%$ .

The plumbing connections are located on the rear of the unit and are labelled SUPPLY and RETURN. These connections are  $\frac{3}{4}$  inch FPT. Remove the plastic protective plugs from both plumbing connections. Connect the SUPPLY fitting to the inlet of your application. Connect the RETURN fitting to the outlet of your application.

To fill the reservoir open the access panel on the left rear corner of the case top and remove the reservoir cover by unscrewing the thumbscrews. Fill the reservoir to within one inch of the top. If the fluid capacity of your application and recirculation lines are significant, have extra fluid on hand.

Tap water is the recommended fluid for operation from +8°C to +80°C. Below +8°C, a non-freezing fluid must be used. A mixture of tap water and laboratory grade ethylene glycol is suggested.

### Operation

Before starting the unit, double check all electrical and plumbing connections. Make sure the circulating system has been filled with cooling fluid.

On models HX-200 through HX-750, the unit must be connected to the power source for at least 12 hours to allow the oil to be heated and separated from the refrigerant

To start the unit, place the circuit breaker located on the rear of the unit to the on position. The MAIN indicator will illuminate. Place the ON/OFF switch to the ON position then press the ON/OFF key on the temperature controller. The unit will start and the SYSTEM and SYS ON indicators will illuminate. The controller will indicate the temperature of the reservoir fluid.

When the unit is shut off, wait five minutes before restarting to allow time for the refrigeration pressures to equalize. If the pressures are not allowed to equalize, the compressor will short-cycle and no cooling will occur.

### Temperature Adjustment

To display the temperature setpoint, while in the Operator's Loop press and NEXT key. To adjust the temperature setpoint use the Setup Loop as described in this manual.

### Flow Control

The RECIRCULATING FLOW CONTROL handle controls the flow rate to your application. In the "+" position you receive full flow, the "-" position is no flow.

### Periodic Maintenance

Periodically inspect the reservoir fluid. If cleaning is necessary, flush the reservoir with a cleaning fluid compatible with the circulating system and the cooling fluid.

The cooling fluid should be replaced periodically. When operating at low temperatures, the concentration of water in the cooling fluid will increase over time, leading to a loss of cooling capacity.

Periodic vacuuming of the condenser fins is necessary. The frequency of cleaning depends on the operating environment. We recommend a visual inspection of the condenser be made monthly after initial installation. After several months, the cleaning frequency will be established.

Units with PD and TU pumps have a strainer. If debris is in the system, the strainer will prevent the material from being drawn into the pump and damaging the pump vanes.

After initial installation, the strainer may become clogged. The strainer must be cleaned after the first week of installation. After this first cleaning, a monthly visual inspection is recommended. After several months, the frequency of cleaning will be established.

Before cleaning the strainer, disconnect the power cord from the power source and drain the reservoir.

## **Quik Start Procedures Water-Cooled Models**

### **Installation**

Position the unit in a clean environment with easy access to facility cooling water and a drain. The facility water requirements must meet those specified in the instruction or unit performance will be derated.

Ensure the voltage of the power source meets the specified voltage,  $\pm 10\%$ .

The plumbing connections are located on the rear of the unit and are labelled TAP WATER, DRAIN, SUPPLY and RETURN. Remove the plastic protective plugs from all the plumbing connections. Connect the TAP WATER fitting to the facility cooling water and the DRAIN fitting to a drain. Connect the SUPPLY fitting to the inlet of your application and the RETURN fitting to the outlet of your application.

To fill the reservoir open the access panel on the left rear corner of the case top and remove the reservoir cover by unscrewing the thumbscrews. Fill the reservoir to within one inch of the top. If the fluid capacity of your application and recirculation lines are significant, have extra fluid on hand.

Tap water is the recommended fluid for operation from  $+8^{\circ}\text{C}$  to  $+80^{\circ}\text{C}$ . Below  $+8^{\circ}\text{C}$ , a non-freezing fluid must be used. A mixture of tap water and laboratory grade ethylene glycol is suggested.

### **Operation**

Before starting the unit, double check all electrical and plumbing connections. Make sure the circulating system has been filled with cooling fluid.

Ensure the facility water is turned on.

On models HX-200 through HX-750, the unit must be connected to the power source for at least 12 hours to allow the oil to be heated and separated from the refrigerant

To start the unit, place the circuit breaker located on the rear of the unit to the on position. The MAIN indicator will illuminate. Place the ON/OFF switch to the ON position then press the ON/OFF key on the temperature controller. The unit will start and the SYSTEM and SYS ON indicators will illuminate. The controller will indicate the temperature of the reservoir fluid.

When the unit is shut off, wait five minutes before restarting to allow time for the refrigeration pressures to equalize. If the pressures are not allowed to equalize, the compressor will short-cycle and no cooling will occur.

### **Temperature Adjustment**

To display the temperature setpoint, while in the Operator's Loop press and NEXT key. To adjust the temperature setpoint use the Setup Loop as described in this manual.

### **Flow Control**

The RECIRCULATING FLOW CONTROL handle controls the flow rate to your application. In the "+" position you receive full flow, the "-" position is no flow.

### **Periodic Maintenance**

Periodically inspect the reservoir fluid. If cleaning is necessary, flush the reservoir with a cleaning fluid compatible with the circulating system and the cooling fluid.

The cooling fluid should be replaced periodically. When operating at low temperatures, the concentration of water in the cooling fluid will increase over time, leading to a loss of cooling capacity.

Periodic vacuuming of the condenser fins is necessary. The frequency of cleaning depends on the operating environment. We recommend a visual inspection of the condenser be made monthly after initial installation. After several months, the cleaning frequency will be established.

Units with PD and TU pumps have a strainer. If debris is in the system, the strainer will prevent the material from being drawn into the pump and damaging the pump vanes.

After initial installation, the strainer may become clogged. The strainer must be cleaned after the first week of installation. After this first cleaning, a monthly visual inspection is recommended. After several months, the frequency of cleaning will be established.

Before cleaning the strainer, disconnect the power cord from the power source and drain the reservoir.

## Preface

### Compliance

Products tested and found to be in compliance with the requirements defined in the EMC standards defined by 89/336/EEC as well as Low Voltage Directive (LVD) 73/23/EEC can be identified by the CE label on the rear of the unit. The testing has demonstrated compliance with the following directives:

LVD, 73/23/EEC	Complies with UL 3101-1:93
EMC, 89/336/EEC	EN 55011, Class A Verification EN 50082-1:1992 IEC 1000-4-2:1995 IEC 1000-4-3:1994 IEC 1000-4-4:1995

For any additional information refer to the Letter of Compliance that shipped with the unit (Declaration of Conformity).

### Unpacking

Retain all cartons and packing material until the unit is operated and found to be in good condition.

On units with a remote control box, the box is packed in a separate carton. Be sure to locate this separate carton; do not dispose of it by mistake.

If the unit shows external or internal damage, or does not operate properly, contact the transportation company and file a damage claim. Under ICC regulations, this is your responsibility.

### Warranty

The unit has a warranty against defective parts and workmanship for one full year from date of shipment. Refer to the last page of this manual for complete warranty details.

### After-sale Support

NESLAB is committed to customer service both during and after the sale. If you have questions concerning the operation of your unit or the information in this manual, contact our Sales Department. If your unit fails to operate properly or if you have questions concerning spare parts or Service Contracts, contact our Service Department.

Before calling, please refer to the serial number label on the rear of the case top to obtain the following information (see Section II, Description for the serial number label location):

- *BOM number* \_\_\_\_\_

- *Serial number* \_\_\_\_\_

## Section I Safety

### Warnings

Make sure you read and understand all instructions and safety precautions listed in this manual before installing or operating your unit. If you have any questions concerning the operation of your unit or the information in this manual, contact our Sales Department for assistance (see Preface, After-sale Support).

**Performance of installation, operation, or maintenance procedures other than those described in this manual may result in a hazardous situation and may void the manufacturer's warranty.**

**Transport the unit with care. Sudden jolts or drops can damage the refrigeration lines.**

**Do not attempt to defeat any of the interlock switches or safety features built into the unit.**

**Observe all warning labels.**

**Never remove warning label.**

**Never operate damaged or leaking equipment.**

**Never operate the unit without cooling fluid in the fluid reservoir.**

**Make sure the unit is off before connecting or disconnecting the power cord or other cables.**

**Always turn off the unit and disconnect the power cord from the power source before performing any service or maintenance procedures, or before moving the unit.**

**Always empty the fluid reservoir before moving the unit.**

**Never operate equipment with damaged power cords.**

**Refer service and repairs to a qualified NESLAB technician.**

In addition to the safety warnings listed above, warnings are posted throughout the manual. These warnings are designated by an exclamation mark inside an equilateral triangle with text highlighted in bold. Read and follow these important instructions. Failure to observe these instructions can result in permanent damage to the unit, significant property damage, or personal injury or death.

## Section II General Information

### Description

The HX Series Recirculating Chiller is designed to provide a continuous flow of cooling fluid at a constant temperature and volume.

The unit consists of an air-cooled or water-cooled refrigeration system, a fluid reservoir, a fluid recirculation pump, and a temperature controller.

HX units are available with a large number of options. This manual explains how to install, operate, and maintain a “standard” HX unit. This manual also explains some of the available options. Supplemental manuals are supplied with units equipped with options not covered in this manual.

Throughout the manual, you will be asked to consult the unit’s serial number label, or the pump identification label, or both, for specific information. Both labels are located on the rear of the case top.

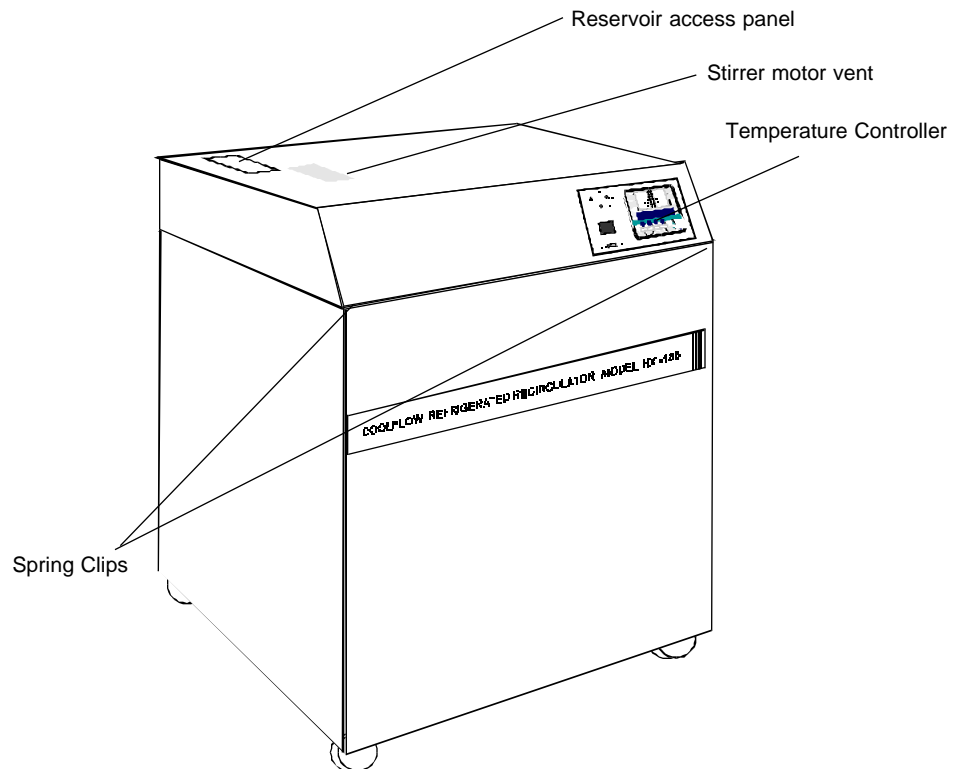

## Specifications

	HX-75	HX-100	HX-150	
<b>Temperature Range</b>	+5°C to +35°C			
<b>Temperature Stability</b>	±0.1°C			
<b>Unit Dimensions</b> (H x W x D) <i>Inches</i> <i>Centimeters</i>	36 ¾ x 23 ¼ x 18 ¾ 93.3 x 59.0 x 47.6	40 5/8 x 26 ¼ x 21 1/8 103.2 x 66.6 x 53.6		
<b>Reservoir Volume</b> <i>Gallons</i> <i>Liters</i>	5.0 19.0	8.0 30.3		
<b>Shipping Weight</b> <i>Pounds</i> <i>Kilograms</i>	261 118	300 136	320 145	
	HX-200	HX-300	HX-500	HX-750
<b>Temperature Range</b>	+5°C to +35°C			
<b>Temperature Stability</b>	±0.1°C			
<b>Unit Dimensions<sup>1</sup></b> (H x W x D) <i>Inches</i> <i>Centimeters</i>	46 7/8 x 33 ¾ x 25 ¼ 119.1 x 85.7 x 64.1	51 5/8 x 46 x 28 ¾ 131.1 x 116.8 x 73.0	64 ¾ x 46 x 29 163.2 x 116.8 x 73.6	
<b>Reservoir Volume</b> <i>Gallons</i> <i>Liters</i>	15.0 56.8	28.0 106.0	40.0 151.0	
<b>Shipping Weight</b> <i>Pounds</i> <i>Kilograms</i>	471 214	531 241	746 338	971 440

1. The model HX-750 with a water-cooled refrigeration system has the same dimensions as the HX-500. For additional dimensions see page 46.

## Cooling Capacity

Cooling capacity will vary depending on fluid temperature, ambient temperature, and cooling fluid.

Cooling capacities for models HX-75 through HX-750 were obtained under the following conditions:

1. air-cooled unit operating at +20°C (+68°F) ambient temperature.
2. cooling fluid with specific heat of 1.0 was used for fluid temperatures from +5°C to +35°C.

### HX-75, 100, & 150

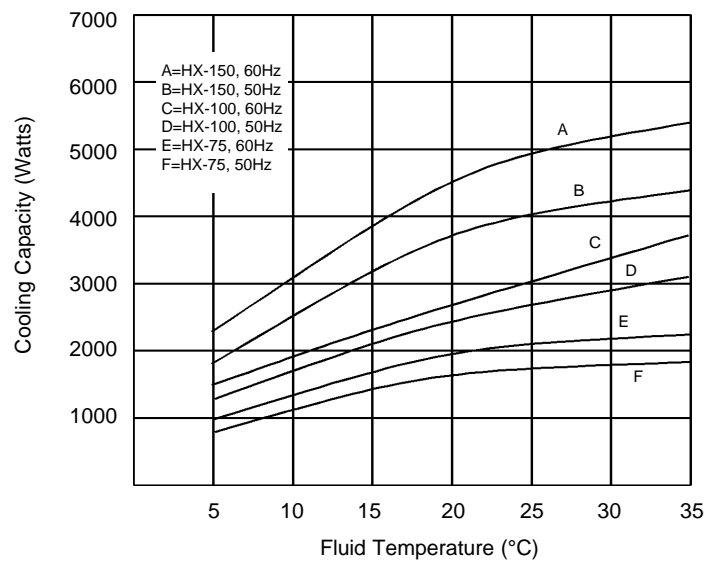

### HX-200 & 300

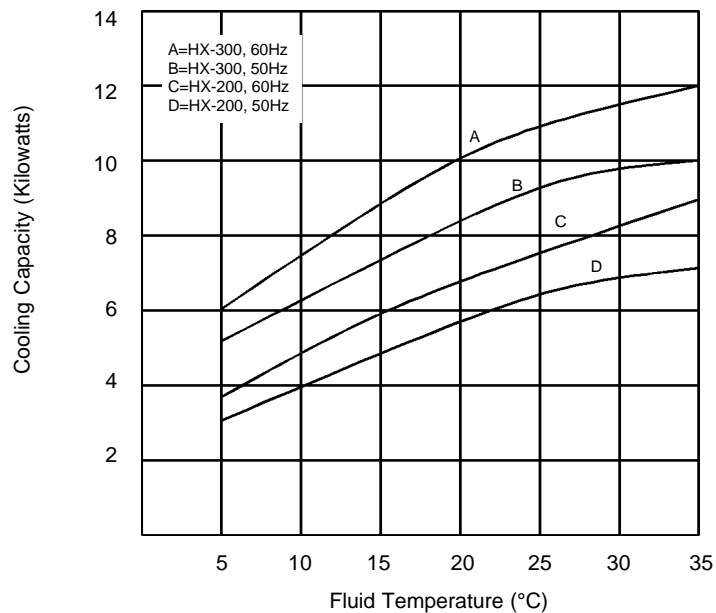

## HX-500 & 750

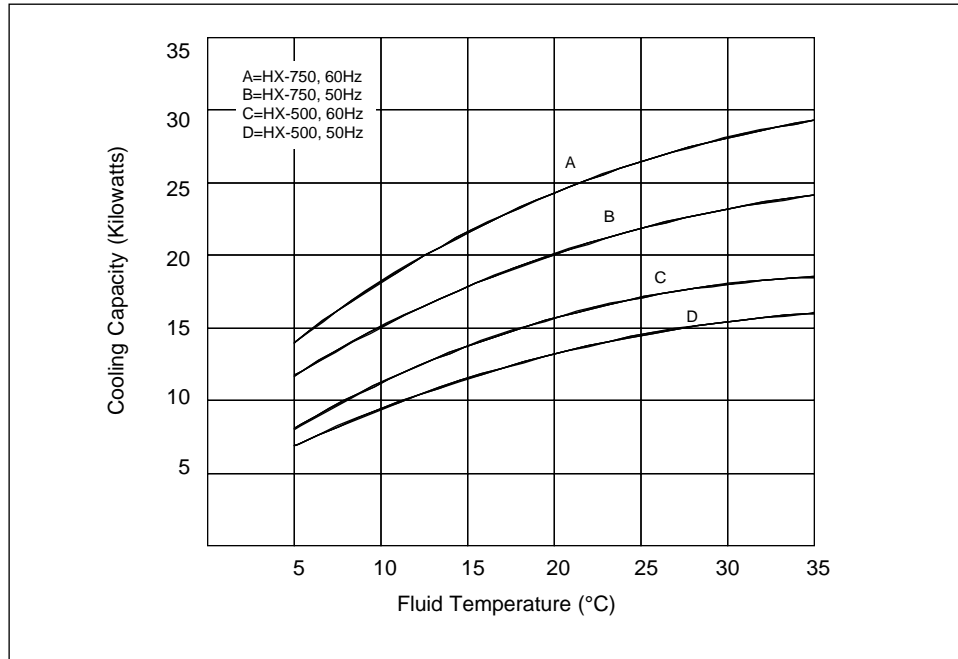

## Pump Capacity

HX units are available with one of three standard pump types: positive displacement (PD), centrifugal (CP), and turbine (TU). Refer to the pump identification label on the rear of the case top or rear of analog temperature controller to identify the specific pump in your unit.

## PD1, PD2 & TU1

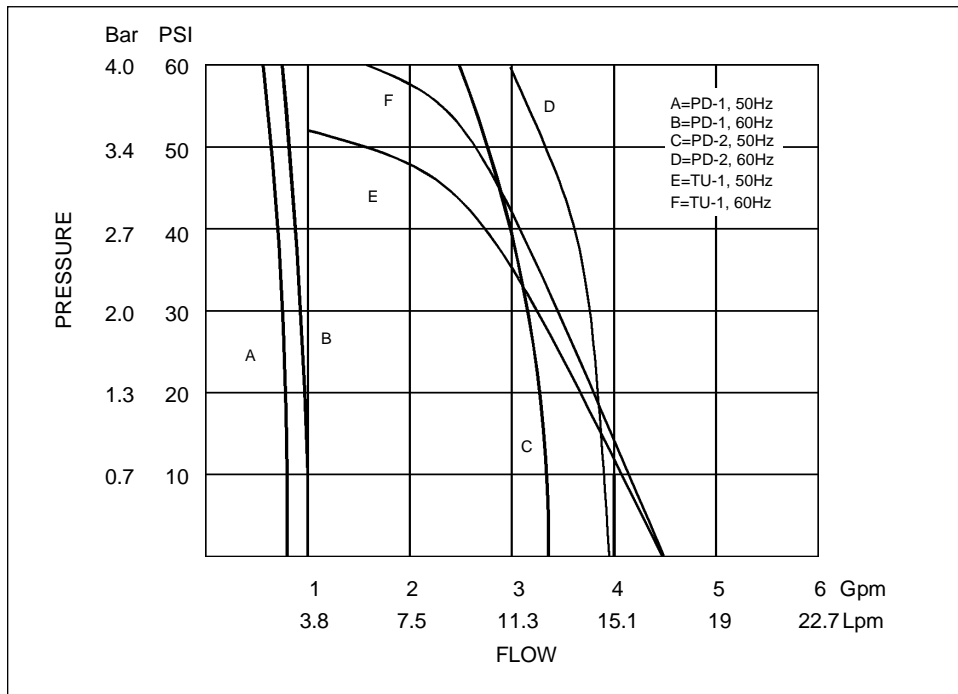

**CP**

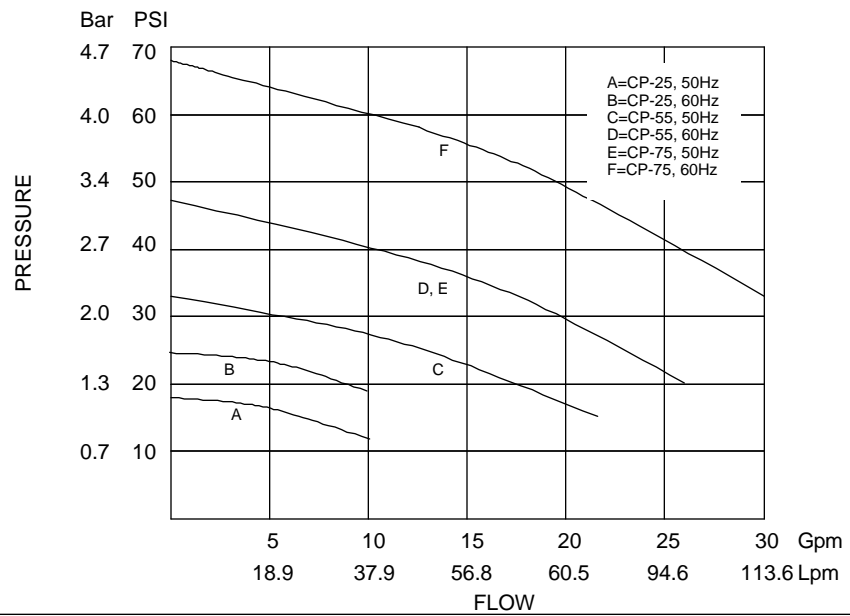

**TU-3, 5 & 6**

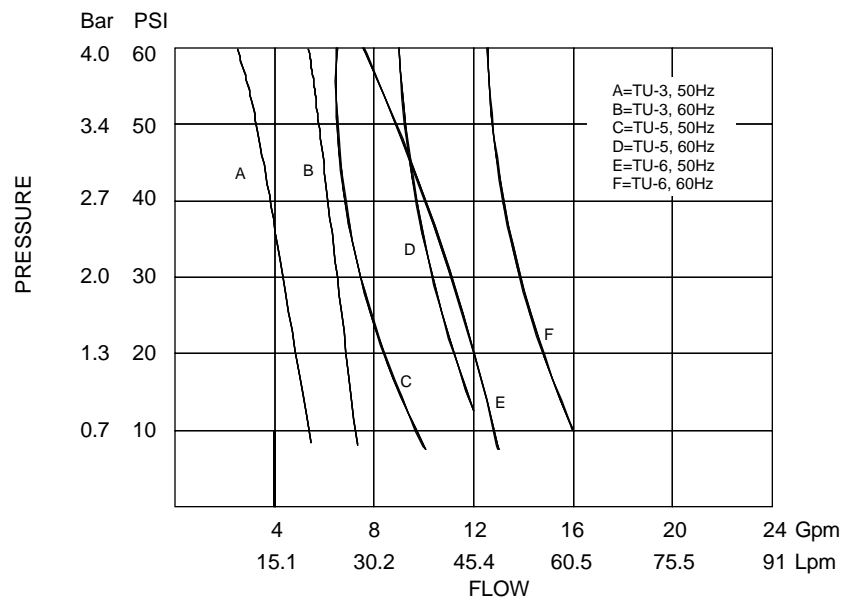

**TU-7, 8 & 9**

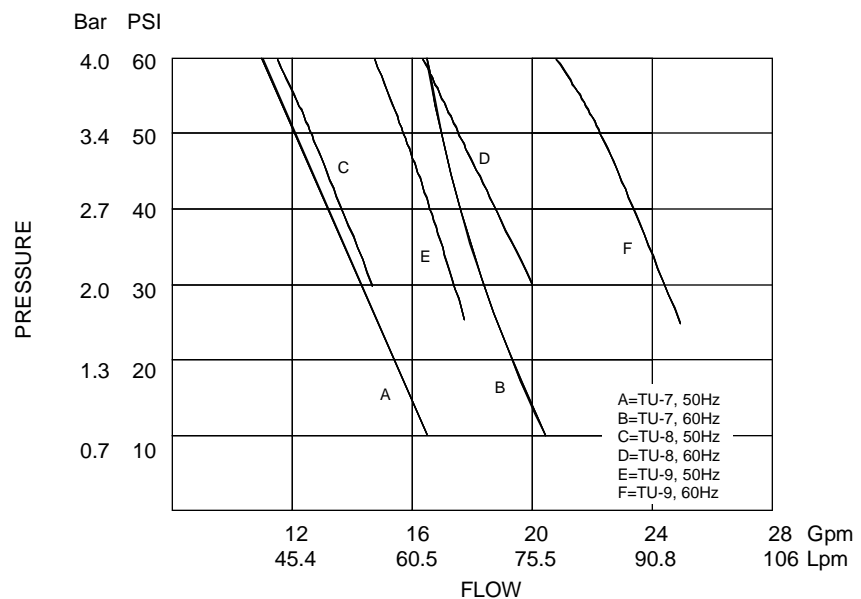

## Section III Installation

### Site (Air-cooled Units)

The unit should be located in a laboratory or clean industrial environment where ambient temperatures are inside the range of +55°F to +95°F (+13°C to +35°C).

The unit will retain its full rated capacity in ambient temperatures to approximately +75°F (+24°C). Above +75°F, derate the cooling capacity 1% for every 1°F above +75°F, to a maximum ambient temperature of +95°F. In degrees Celsius, derate the cooling capacity 1% for every 0.5°C above +24°C, to a maximum ambient temperature of +35°C.



**Never place the unit in a location where excessive heat, moisture, or corrosive materials are present.**

The unit has an air-cooled refrigeration system. It must be positioned so the air intake and discharge are not impeded.

On models HX-75 through HX-150, air is drawn through the left side of the unit and discharged through the right and rear. A minimum clearance of 2 feet (0.6 meter) on these three sides is necessary for adequate ventilation.

On models HX-200 through HX-750, air is drawn through the front of the unit and discharged through the side and rear panels. A minimum of 5 feet (1.5 meters) on all four sides of the unit is necessary for ventilation.

In some applications where space is at a premium, the minimum ventilation clearance can be compromised. However, consult our Sales Department before positioning the unit in a location with less minimum clearance than listed above. Inadequate ventilation will cause a reduction in cooling capacity and, in extreme cases, compressor failure.

Excessively dusty areas should be avoided and a periodic cleaning schedule should be instituted (see Section VII, Condenser Cleaning).

On models HX-100 through HX-750 the stirrer motor is located under the case top. (Models HX-500 and HX-750 have two stirrer motors.) Heat generated by the stirrer motor is discharged through vents in the case top. Do not block the vents. A minimum clearance of 2 inches (5 centimeters) is necessary for adequate ventilation. See illustration on page 7.

**NOTE:** Units with plate heat exchangers do not have stirrer motors.

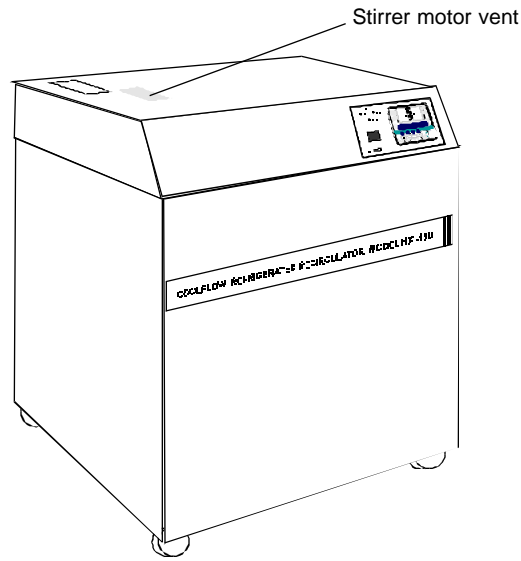

**NOTE:** The HX-750 380/480V model contains a three phase condenser fan motor. It is possible to misconnect the main power and have the motor turn in the wrong direction resulting in incorrect airflow over the condenser. Proper airflow is achieved by exchanging any two main power connectors.

Refer to the table below to determine the approximate amount of air intake required for the unit to retain its full rated capacity. If the air intake does not meet these standards, cooling capacity will be derated.

	<b>HX-75</b>	<b>HX-100</b>	<b>HX-150</b>	<b>HX-200</b>
<b>Air Intake</b>				
<i>Cubic feet per minute</i>	600	710	1050	2000
<i>Liters per minute</i>	17000	20100	29730	56640
	<b>HX-300</b>		<b>HX-500</b>	<b>HX-750</b>
<b>Air Intake</b>				
<i>Cubic feet per minute</i>	1900		5000	5600
<i>Liters per minute</i>	53800		141750	158800

## Site (Water-cooled units)

The unit should be located in a laboratory or clean industrial environment with easy access to a facility cooling water supply and a drain.

All units are equipped with castors for easy movement. This allows the unit to be placed in a small area, as long as there is ample space for the unit to be moved for access on all four sides. A minimum access clearance of 3 feet (1 meter) on two adjacent sides is recommended.

The facility cooling water supply must meet or exceed the requirements listed in the table shown on the next page for the unit to operate at its full rated capacity. If the facility cooling water does not meet these standards, the cooling capacity will be derated.

As the temperature of the cooling water supply increases, the required flow rate and pressure of the cooling water supply increases.

For example, with a model HX-150, if the temperature of the cooling water supply is +65°F, the flow rate must be at least 1.5 gallons per minute, with a pressure differential of at least 3.5 PSI. However, if the temperature of the cooling water supply is +85°F, the flow rate must be at least 4.0 gallons per minute, with a pressure differential of at least 10 PSI.

If the unit is being used with a building water supply, the back pressure of the drain must be less than the supply pressure.

A water regulating valve, located in the TAP WATER line, regulates the flow rate of the cooling water supply as it enters the unit. The valve regulates the flow rate based on the heat load. Flow through the unit stops automatically when the unit is shut off.

On models HX-100 through HX-750 the stirrer motor is located under the case top. (Models HX-500 and HX-750 have two stirrer motors.) Heat generated by the stirrer motor is discharged through vents in the case top. Do not block the vents. A minimum clearance of 2 inches (5 centimeters) is necessary for adequate ventilation. See illustration on page 7.

**NOTE:** Units with plate heat exchangers do not have stirrer motors.

Temperature of cooling water supply				
	+55°F (+13°C)	+65°F (+18°C)	+75°F (+24°C)	+85°F (+29°C)
<b>HX-75</b>				
<b>Flow Rate</b>				
<i>Gallons per minute</i>	0.75*	1.0	1.5	3.0
<i>Liters per minute</i>	2.8*	3.7	5.7	11.4
<b>Pressure Drop</b>				
<i>PSI</i>	1.5*	2.0	3.5	8.0
<i>Bar</i>	0.10*	0.13	0.24	0.55
<b>HX-100</b>				
<b>Flow Rate</b>				
<i>Gallons per minute</i>	1.0*	1.5	2.0	3.5
<i>Liters per minute</i>	3.8*	5.7	7.6	13.2
<b>Pressure Drop</b>				
<i>PSI</i>	2.0*	3.5	5.0	10.0
<i>Bar</i>	0.13*	0.24	0.34	0.69
<b>HX-150</b>				
<b>Flow Rate</b>				
<i>Gallons per minute</i>	1.0*	1.5	2.5	4.0
<i>Liters per minute</i>	3.8*	5.7	9.5	15.1
<b>Pressure Drop</b>				
<i>PSI</i>	2.0*	3.5	6.0	10.0
<i>Bar</i>	0.13*	0.24	0.41	0.69
<b>HX-200</b>				
<b>Flow Rate</b>				
<i>Gallons per minute</i>	1.8*	2.5	3.5	6.0
<i>Liters per minute</i>	6.8*	9.5	13.2	22.7
<b>Pressure Drop</b>				
<i>PSI</i>	5.0*	6.0	7.0	18.0
<i>Bar</i>	0.34*	0.41	0.48	1.24
<b>HX-300</b>				
<b>Flow Rate</b>				
<i>Gallons per minute</i>	2.5*	4.0	6.5	11.0
<i>Liters per minute</i>	9.5*	15.1	24.6	41.6
<b>Pressure Drop</b>				
<i>PSI</i>	6.0*	8.0	13.5	25.0
<i>Bar</i>	0.41*	0.55	0.93	1.72
<b>HX-500</b>				
<b>Flow Rate</b>				
<i>Gallons per minute</i>	3.5	5.0	8.0	16.0
<i>Liters per minute</i>	13.2	18.9	30.3	60.6
<b>Pressure Drop</b>				
<i>PSI</i>	13.0	17.0	23.0	57.0
<i>Bar</i>	0.89	1.17	1.58	3.93
<b>HX-750</b>				
<b>Flow Rate</b>				
<i>Gallons per minute</i>	6.0	8.0	12.5	16.6
<i>Liters per minute</i>	22.7	30.3	47.3	62.8
<b>Pressure Drop</b>				
<i>PSI</i>	14.0	20.0	28.5	40.0
<i>Bar</i>	0.96	1.38	1.96	2.76

\*Estimator Value

## Electrical Requirements

Refer to the table below to determine the unit's electrical requirements. Verify the requirements by reviewing the ratings listed on the serial number label on the rear of the case top or rear of analog temperature controller.

	HX-75		HX-100		HX-150			
Volts			208/230	220/240				
Hertz			60	50				
Phase			1	1				
Plug	NEMA L6-30P or L6-20P							
	HX-200		HX-300		HX-500		HX-750	
Volts	208/230	200/220	380/420		208/230		380/420	
Hertz	60	50	50		60		50	
Phase	3	3	3		3		3	
Plug	NEMA L15-30P or L16-20P				N/A			

Make sure the voltage of the power source agrees with the unit's voltage and frequency rating. The unit is designed to tolerate deviations of  $\pm 10\%$  from the rated line voltage.

Models HX-75 through HX-300 have an 8 foot (2.4 meter) power cord installed on the unit at the time of shipment.

**NOTE:** Custom units equipped with heaters may not have a power cord. See Section VI, Special Features.

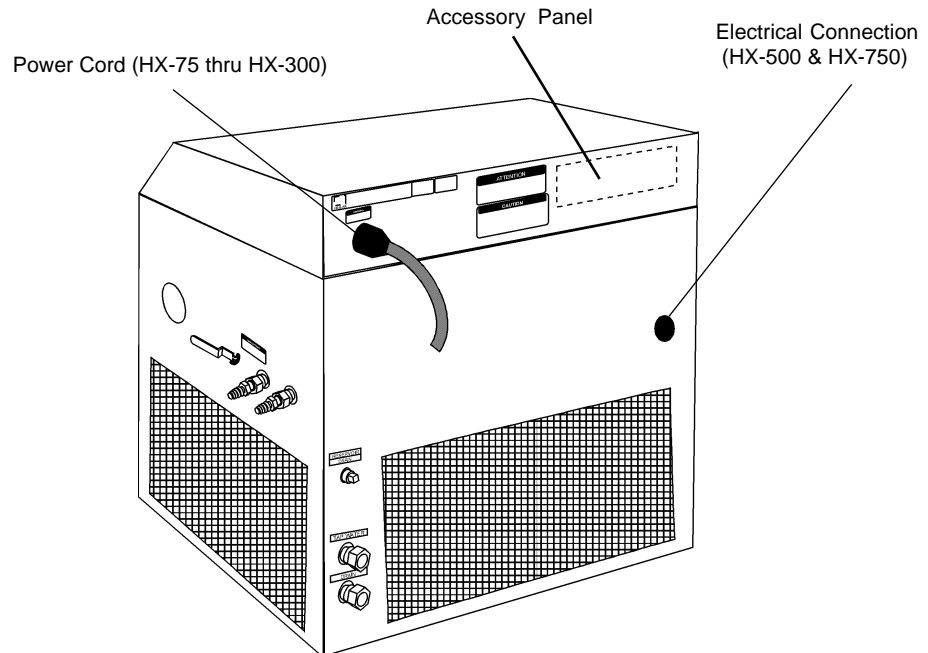



**The unit construction provides extra protection against the risk of electric shock by grounding appropriate metal parts. The extra protection may not function unless the power cord is connected to a properly grounded outlet. It is the user's responsibility to assure a proper ground connection is provided.**

Models HX-500 and HX-750 are not equipped with a power cable. Installation of the cable is the user's responsibility. Wire the unit in conformance to local, state, and federal electrical codes. Double check all wiring to make sure it is properly connected and protected from the elements.

Models HX-200 through HX-750 are equipped with a compressor crankcase heater. The crankcase heater warms the oil in the compressor and prevents refrigerant from mixing with the oil. Before start up, the unit must be connected to its power source for at least 12 hours. This allows time for the oil to be heated and separate from the refrigerant.

## **Plumbing Requirements**

### **Air-cooled and water-cooled units**

Before installing the unit to an instrument that previously used tap water as a cooling fluid, flush the instrument several times to remove any rust or scale that has built up. Consult the manufacturer of the instrument for a cleaning fluid recommendation.

The plumbing fittings used to connect the HX to the instrument being cooled are located on the right side of the unit (labelled SUPPLY and RETURN). These connections are  $\frac{3}{4}$  inch FPT.

Remove the protective plugs from the SUPPLY and RETURN connections. Connect the SUPPLY fitting to the inlet of the instrument being cooled. Connect the RETURN fitting to the outlet of the instrument being cooled.

The RESERVOIR DRAIN connection, located on the rear of the unit, is a  $\frac{1}{2}$  inch FPT fitting connected internally to the unit's fluid reservoir. This fitting is for draining the reservoir. The unit is shipped with a  $\frac{1}{2}$  inch MPT plug installed in this fitting. Remove the plug to drain the reservoir.

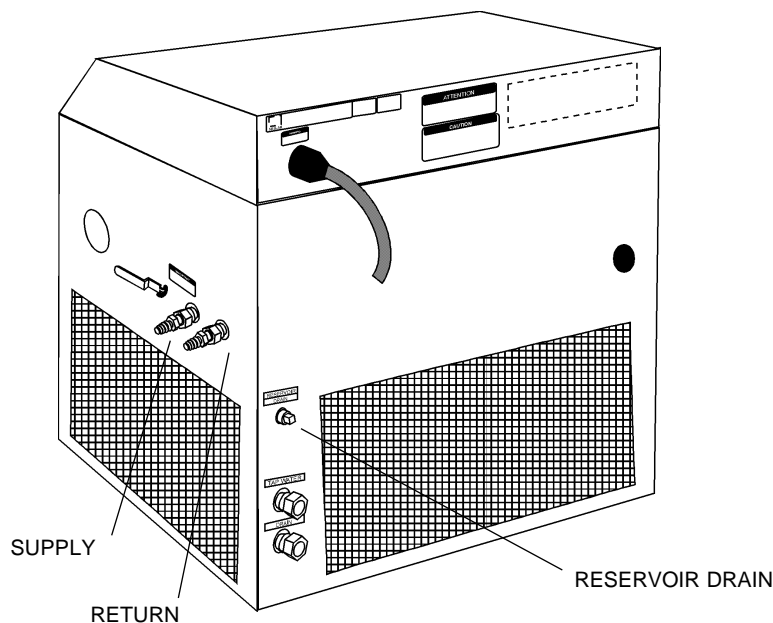

Two plumbing adapters ( $\frac{3}{4}$  inch MPT x  $\frac{5}{8}$  inch hose) are included with the unit. If the unit is being plumbed to the instrument being cooled using flexible tubing, install the adapters in the SUPPLY and RETURN plumbing ports. To prevent leaking, wrap the threads of the adapters with Teflon<sup>®</sup> sealing tape before installing them in the plumbing ports. The adapters will accept  $\frac{1}{2}$  or  $\frac{5}{8}$  inch ID flexible tubing.

If the unit is "hard plumbed" to the instrument being cooled or to the cooling water supply, damage can occur if the unit is bumped or jolted from its site. Provisions should be made to prevent the unit from being moved after installation. Once the unit is plumbed, secure the locking castors on the unit's base. If the unit is located in a heavy traffic area where the possibility of collision is imminent, it may be necessary to secure the unit to the site using blocks or mounting brackets.

Flexible tubing, if used, should be heavy wall or reinforced construction. All tubing should be rated to withstand 110 psi at +35°C. Make sure all tubing connections are securely clamped. Avoid running tubing near radiators, hot water pipes, etc. If substantial lengths of tubing are necessary, insulation may be required to prevent loss of cooling capacity.

Tubing and insulation are available from NESLAB. Contact our Sales Department for more information (see Preface, After-sale Support).

It is important to keep the distance between the unit and the instrument being cooled as short as possible, and to use the largest diameter tubing practical. Tubing should be straight and without bends. If diameter

reductions must be made, they should be made at the inlet and outlet of the instrument being cooled, not at the HX.

If substantial lengths of connecting tubing are required, they should be pre-filled with cooling fluid before connecting them to the unit.

### **Water-cooled units**

The plumbing connections used to connect the water-cooled condenser in the HX to the facility cooling water supply are located at the rear of the unit (labelled TAP WATER and DRAIN). On models HX-75 through HX-300, these fittings are ½ inch FPT. On models HX-500 and HX-750, these fittings are 1 inch FPT.

Remove the plastic protective plugs from the TAP WATER and DRAIN connections. Connect the TAP WATER fitting to the facility cooling water supply. Connect the DRAIN fitting to a drain.

## **Fluids**

The selected cooling fluid must have a viscosity of 50 centistokes or less at the lowest operating temperature.



**If your unit is equipped with a plate heat exchanger, do not use 100% water as a recirculating fluid. Due to the physical nature of a plate heat exchanger, and its response to temperature changes, using 100% water may cause the plate heat exchanger to rupture.**



**Never use flammable or corrosive fluids with this unit. Distilled and deionized water may be aggressive and cause material corrosion. Please contact NESLAB before subjecting this unit to prolonged exposure to distilled or deionized water.**

Tap water is the recommended fluid for operation from +8°C to +35°C. See Water Quality Standards and Recommendations in this section.

Below +8°C, a non-freezing solution is required. A 50/50 mixture, by volume, of water and laboratory grade ethylene glycol is suggested.



**Do not use automobile anti-freeze. Commercial anti-freeze contains silicates that can damage the pump seals. Use of automobile anti-freeze will void the manufacturer's warranty.**

For units with extended temperature ranges above +35°C, tap water is the recommended fluid up to +80°C. Above +80°C, the user is responsible for the fluid(s) used.

## Water Quality Standards and Recommendations

	Permissible(PPM)	Desirable(PPM)
<b>Microbiologicals</b>		
(algae,bacteria,funghi)	0	0
<b>Inorganic Chemicals</b>		
Calcium	<40	0.6
Chloride	250	<25
Copper	1.3	1.0
Iron	0.3	<0.1
Lead	0.015	0
Magnesium	<12	0.1
Manganese	0.05	<0.03
Nitrates\Nitrites	10 as N	0
Potassium	<20	0.3
Silicate	25	<1.0
Sodium	<20	0.3
Sulfate	250	<50
Hardness	17	<0.05
Total Dissolved Solids	50	10
<b>Other Parameters</b>		
pH	6.5-8.5	7-8
Resistivity	0.01*	0.05-0.1*
* Megohm-Cm (Compensated at 25C)		

Unfavorably high total ionized solids (TIS) can accelerate the rate of galvanic corrosion. These contaminants can function as electrolytes which increase the potential for galvanic cell corrosion and lead to localized corrosion such as pitting which can be observed at the studs and on the outside surface of cooling coils. Eventually, the pitting will become so extensive that the coil will leak refrigerant into the water reservoir.

As an example, raw water in the United States averages 171 ppm (as NaCl). The recommended level for use in a water system is between 0.5 to 5.0 ppm (as NaCl).

Recommendation: Initially fill the tank with distilled/deionized water. Do not use untreated tap water as the total ionized solids level may be too high.

Maintain this water quality at a resistivity of between 1 to 10 megohm-cm (compensated at 25°C) by using a purification system. Although the initial fill may be as high as 10 megohm-cm (compensated at 25°C), the desired level for long time usage is 1 to 3 megohm-cm (compensated at 25°C).

The above two recommendations will reduce the electrolytic potential of the water and prevent or reduce the galvanic corrosion observed.

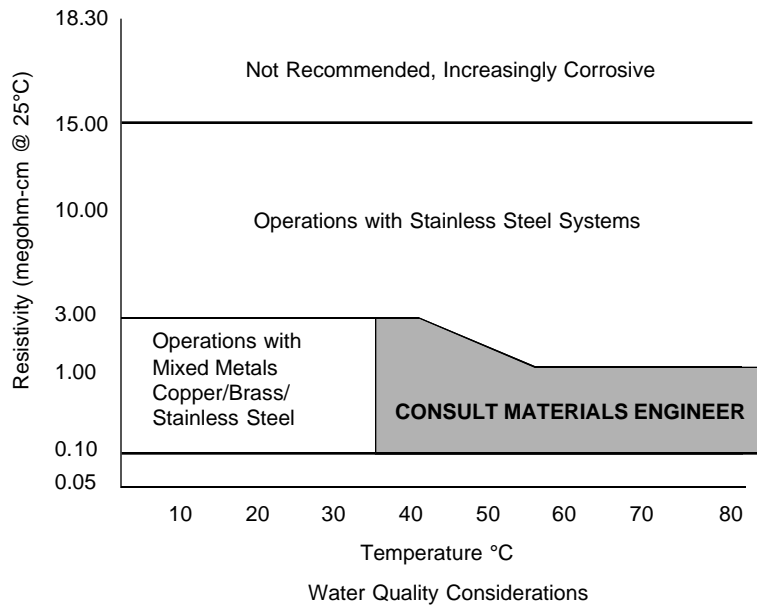

## Filling Requirements

The reservoir access panel is located at the left rear corner of the case top. To open the access panel, slide the latch back (towards the rear of the unit) and lift.

The reservoir cover is located below the access panel. Loosen the thumbscrews and remove the reservoir cover.

Fill the fluid reservoir with cooling fluid to within 1 inch of the top.

The fluid capacity of the instrument being cooled and the recirculation lines may be significant. To prevent the lowering of the fluid level in the reservoir below the operating level, have extra cooling fluid on hand to keep the reservoir filled to within 1 inch of the top.

When the recirculating system is full, replace the reservoir cover and the access panel.

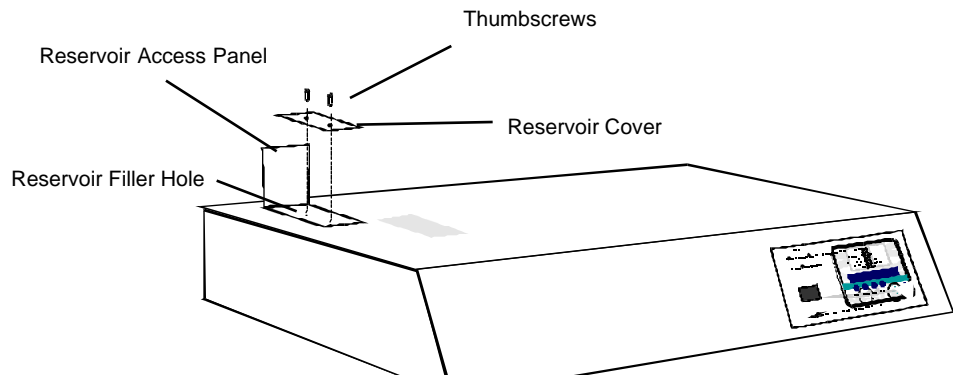

## Section IV Temperature Controller

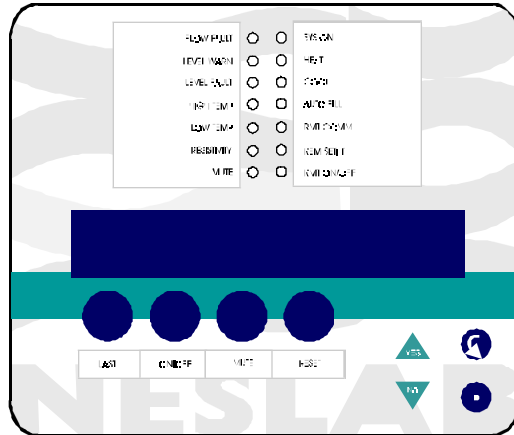

### Controller Keypad

The front panel mounted unit/temperature controller allows the operator to start, control and monitor many features of the unit.

#### **LAST**

Scrolls backward through the menus.

#### **ON/OFF**

Energizes/De-energizes the unit.

#### **MUTE**

Toggles audible alarm silence function for the current alarm. When alarm is silenced, the MUTE LED lights.

#### **RESET**

Clears alarm indications after fault condition has been corrected. Alarm LEDs will remain lit after problem is eliminated to provide indication of problem cause for operator. RESET clears these indicators.

#### **YES, ▲**

Answers Yes to Y/N questions, increments numerical values upward for setting numeric values.

#### **NO, ▼**

Answers NO to Y/N questions, increments numerical values downward for setting numeric values.

#### **NEXT**

Scrolls forward through the menus.

**ENTER**   
Confirms entry of numeric values.

**NOTE:** If NEXT is pressed while the value still flashes, the new value will not be accepted. The display will stop flashing and the original value will be displayed. In this case the NEXT key can be used to abort data entry. The display will not sequence unless the NEXT key is depressed again.

For large Values, the displayed can be changed by manipulating the individual digits. Press YES and NO at the same time, the most significant digit will start to flash. The YES key increments and the NO key decrements the digit. Press the ENTER key to accept the digit and to move to the next most significant digit. Repeat until all digits are entered. Pressing the NEXT key before all digits are entered will abort the procedure and return the display to the original value.

The controller will not allow out to enter a value above the maximum or below the minimum value, or any illegal value. If you try to enter an illegal value the display will revert to its original value when the last digit was entered.

## Status Indicators

Units can be configured in one of two ways. Units are designed to either shut down in the case of a fault, Cutout Option, or, for those customers willing to take the risk of damage to their unit in order to continue providing all available cooling to their application, a Switches Option. Contact our Service Department for more information.

Status indicators are provided to show the state of the various functions.

FLOW FAULT indicates the unit flow is too low. The unit will shut down.

LEVEL WARN indicates the reservoir level is below the float switch mounted in the reservoir. The unit will continue to run.

LEVEL FAULT indicates the reservoir level is too low for safe operation. The unit will shut down.

HIGH TEMP indicates that the reservoir temperature is above the high temperature limit setpoint.

If the reservoir temperature is started above the high limit setpoint the unit will continue to run and the HIGH TEMP indicator will continue to flash until the reservoir setpoint is below the high limit setpoint. Should the reservoir go above the high limit setpoint, a fault will be declared.

LOW TEMP indicates that the reservoir temperature is below the low temperature limit setpoint.

If a unit is started with the a reservoir temperature below the temperature limit setpoint, the unit will run and the LOW TEMP status indicator will continue to flash until the reservoir is above the low limit reservoir overtemperature switch. Should the reservoir temperature subsequently go below the low limit setpoint, a fault will be declared.

RESISTIVITY (Optional) displays measurement value on the controller and a 0-10VDC signal to the analog interface connector on the rear of he unit.

The controller is designed to measure and/or control resistivity. Should the resistivity go above the specific level set in the Setup Loop (see page 27), a warning will be declared.

MUTE indicates the buzzer has been turned off.

SYS ON indicates unit is running.

HEAT indicates a heater in the unit to maintain constant temperature to this application.

COOL indicates the refrigeration system is removing heat from the reservoir system to maintain constant temperature.

As the fluid temperature approaches the temperature setpoint, the COOL indicator cycles on and off to indicate the duty cycle of the system. The unit can be in COOL or HEAT mode, but never both at the same time. A balance between COOL and HEAT controls the temperature.

AUTO FILL (Optional) depends upon configuration of unit to automatically refill the reservoir.

RMT COMM (Optional) indicates the unit receives communication via the optional RS-232 interface from the remote computer equipped with NEScom software.

REM SETPT indicates the temperature is set from the remote computer.

RMT ON/OFF indicates unit is in either the remote or local mode.

## Changing a Value

The **YES** key increments the value. The **NO** key decrements the value.

The display will flash as soon as either key is depressed, and will continue to flash until the **ENTER** key is pressed to accept the new value. The new value will not be used by the controller until the **ENTER** key is depressed and the display stops flashing.

If the **NEXT** key is pressed while the value is flashing, the new value will not be accepted. The display will stop flashing and the original value will be displayed. In this case the **NEXT** key can be used to abort data entry. The display will not sequence unless the **NEXT** key is depressed again.

For large values the display can be changed by manipulating the individual digits. Press the **YES** key and the **NO** key at the same time. The most significant digit will start to flash. The **YES** key increments or the **NO** key decrements the digit. Press the **ENTER** key to accept the digit and to move to the next most significant digit. Repeat until all digits are entered. Pressing the **NEXT** key before all digits are entered will abort the procedure and return the display to the original value.

The controller will not allow you to enter a value above the maximum (+35°C) or below the minimum (5°C). If you try to enter an illegal value outside the operating range, the display will revert to its original value.

## Controller Displays

An alphanumeric display presents numeric readings of various operating conditions within the chiller. Display function is selected by pressing the appropriate keys to move through a menu of available information.

An Operator's Loop and a Setup Loop allow you to display and/or alter different parameters of the controller. The Setup Loop can be accessed from the temperature display by pressing and holding the key combinations shown on Figure 1 on the next page.

When the controller is first powered up it goes through a short self test and then enters the Operator's Loop, displaying the reservoir fluid temperature.

**NOTE:** Should you desire to return to the temperature display and abort any changes, keep pressing the **NEXT** until the display reads **SAVE?** Press **NO**.

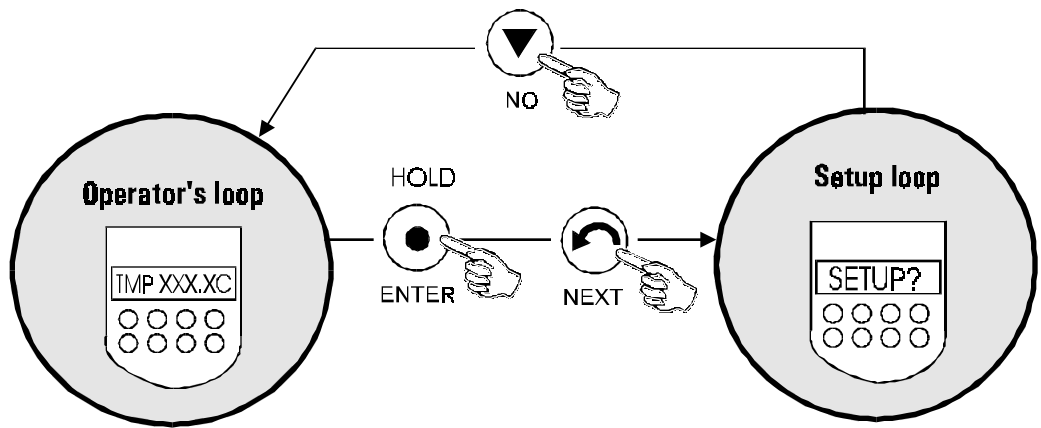
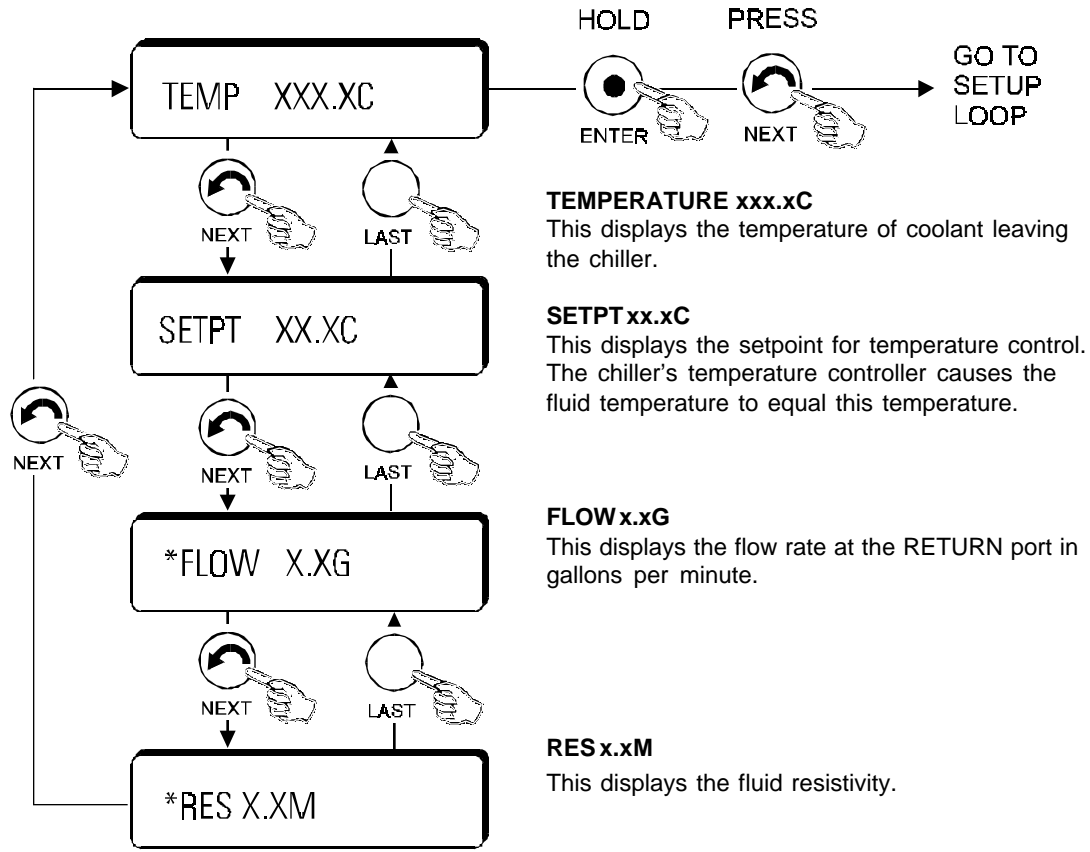

Figure 1 Changing Loops



\* Display is shown only when option is enabled in Configuration Loop, contact our Service Department for assistance.

Figure 2 Operator's Loop

### Setup Loop

The setup loop allows the operator to change temperature and flow limits, and to change the temperature controller's tuning constants.

To enter this loop you must be in the operators loop and displaying temperature, see Figure 2. Depress and hold the **ENTER** key then press **NEXT**. Adjust values with the **YES** and **NO** keys. Press **ENTER** for the controller to accept each new entry.

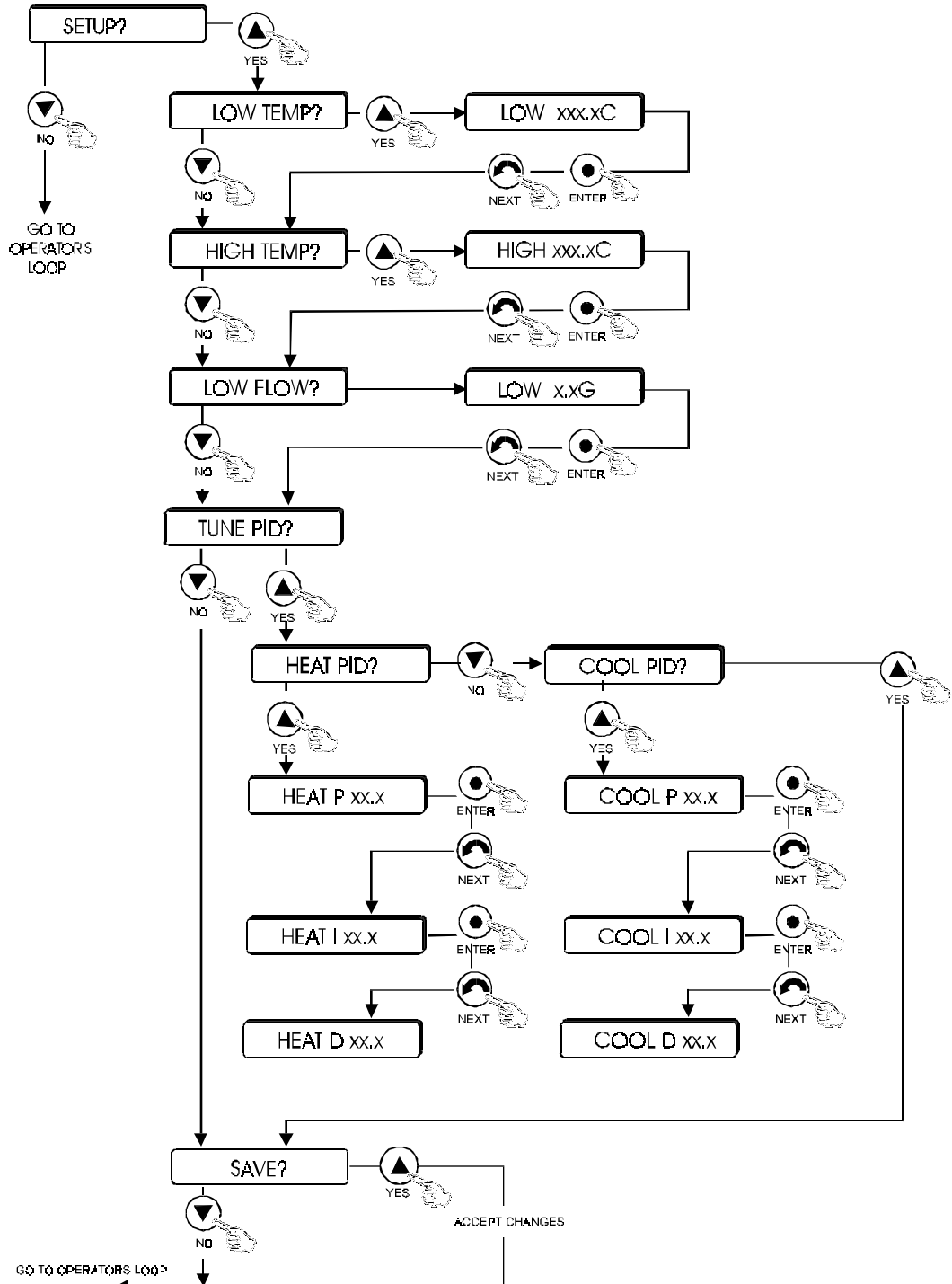

Figure 3 Setup Loop

## Section V Operation

### Flow Control

The RECIRCULATING FLOW CONTROL handle, located on the right-hand side of your unit, is connected to a valve that controls the flow rate of the cooling fluid to the instrument being cooled.

When the handle is in the “+” position, the valve is open and all possible cooling fluid is supplied to the instrument being cooled. When the handle is in the “-” position, the valve is closed and no cooling fluid is supplied to the instrument being cooled. When the handle is between these two positions, the flow rate of the cooling fluid is between full flow and no flow. Use a flow meter on the SUPPLY line to adjust the desired flow rate.

The flow control valve must be opened slightly to allow fluid to circulate through the flow switch that monitors the flow rate. A flow rate of more than 0.3 gallons per minute (1.0 liters per minute) is necessary. If the flow is completely shut off, or if the flow is not adequate, a low flow fault will occur and the unit will not start.



**Never “crank” the valve wide open from the closed or slightly open position.**

### Start Up

For CE Mark units check the circuit breaker setting on the rear of the bonnet. With the breaker on the MAIN indicator will illuminate.

Models HX-200 through HX-750 are equipped with a compressor crankcase heater. The crankcase heater warms the oil in the compressor and prevents refrigerant from mixing with the oil. Before start up, the unit must be connected to its power source for at least 12 hours. This allows time for the oil to be heated and separate from the refrigerant.

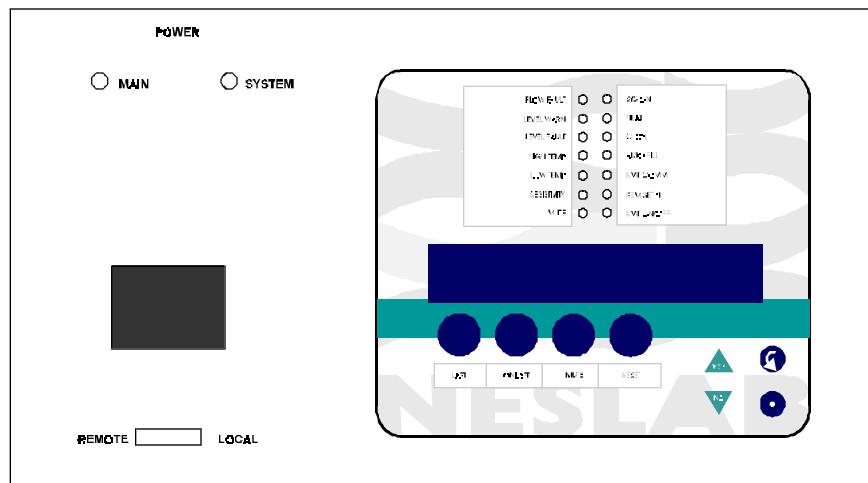



**On water-cooled units, ensure the facility water is on and make sure the cooling water supply is connected to the TAP WATER connection, not the DRAIN connection.**

Press the ON/OFF switch to the ON position. The MAIN indicator will illuminate. Press the ON/OFF key on the temperature controller. The unit will start and the SYSTEM and SYS ON indicators will illuminate. The controller will indicate the temperature of the reservoir fluid.

When the unit is shut off, wait approximately 5 minutes before restarting. This allows time for the refrigeration pressures to equalize. If the pressures are not allowed to equalize, the compressor will short-cycle (clicking sound) and no cooling will occur.

## **Pressure Gauge**

The RECIRCULATING PRESSURE gauge is located next to the flow control handle. The gauge indicates the operating pressure of the system.

## **Pressure Relief Valve (PD and TU Pumps Only)**

Units with a PD-1, PD-2, or any TU type pump have an adjustable pressure relief valve. Refer to the pump identification label on the rear of the case top or rear of analog controller to identify the specific pump in your unit.

The pressure relief valve establishes the maximum operating pressure of the unit. If the pressure of the fluid leaving the pump exceeds the valve setting, the relief valve will bypass the fluid within the unit to relieve the pressure. The valve does not determine the actual operating pressure; the operating pressure of the system is determined by the back pressure of the connected equipment and the setting of the flow control valve. If adjustment seems necessary, consult our Service Department for assistance.

Before calling, refer to the serial number label on the rear of the case top to obtain the following:

- *BOM number*
- *Serial number*

## **High Pressure Cutout (Water-Cooled Units Only)**

Should the unit's refrigeration discharge pressure become too high the high pressure cutout will activate and shut down the unit. High pressures can be caused by a lack of cooling water to the compressor or debris in the refrigeration lines.

Once the cause of the problem has been identified and corrected you must manually reset the cutout. The cutout location depends on the size of your

unit. On the HX-75, it is behind the right side panel, on the HX-100 and HX-150 it is behind the left side panel, and on the HX-200 through HX-750 it is behind the rear panel.

Locate the white reset switch on the high pressure cutout. Press in on the switch until a "click" is heard. If the reset does not "click" the cutout was not activated and the unit shut down occurred for another reason.

## **Pump Motor Overload Protector**

The overload protector prevents the pump motor from exposure to excessive current. If an overload fault occurs, due, for example, to excessive pressure or flow, or excessive ambient temperature, the overload protector will shut off the pump motor. The overload protector will automatically reset after approximately one to two minutes.

If a fault occurs, a SYS FAULT message appears on the controller and the pump will shut down.

The overload protector can be adjusted to require manual resetting after an overload fault. Contact our Service Department for adjustment instructions (see Preface, After-sale Support).

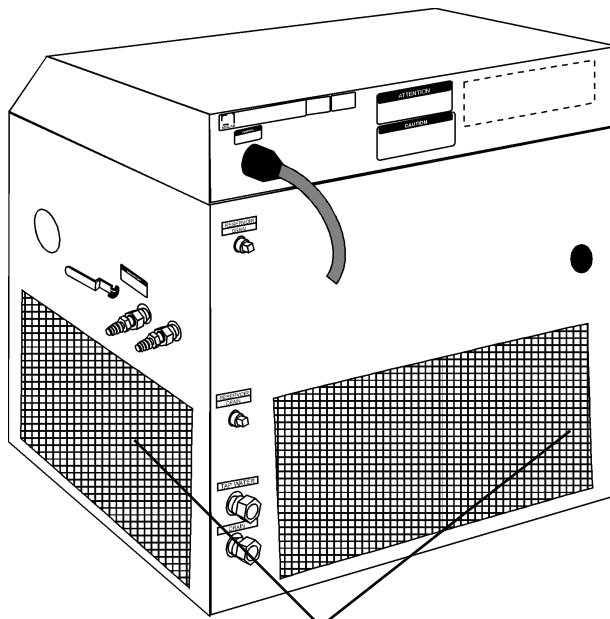

The pump motor overload protector is located directly under the fluid reservoir. It is in the left rear corner for HX200s and HX300s units. It is at the side access panel for HX500s and HX750s units.

## Section VI Optional Features

### Automatic Refill Device

The automatic refill device is designed to maintain the correct level of cooling fluid in the reservoir. The device consists of a float switch in the reservoir and a solenoid valve on top of the reservoir. If the cooling fluid level falls, the float switch will drop, opening the solenoid valve and allowing make-up fluid to fill the reservoir. Once the cooling fluid level reaches the proper level, the float switch will rise and the solenoid valve will close.

The plumbing connection for the refill device is located at the right rear corner of the unit and is labelled AUTO REFILL. This connection is a  $\frac{3}{8}$  inch OD stainless steel barbed fitting.

Connect this fitting to a make-up fluid source using  $\frac{5}{16}$  or  $\frac{3}{8}$  inch ID flexible tubing. Make sure all tubing connections are securely clamped.

Tubing is available from NESLAB. Contact our Sales Department for more information (see Preface, After-sale Support).

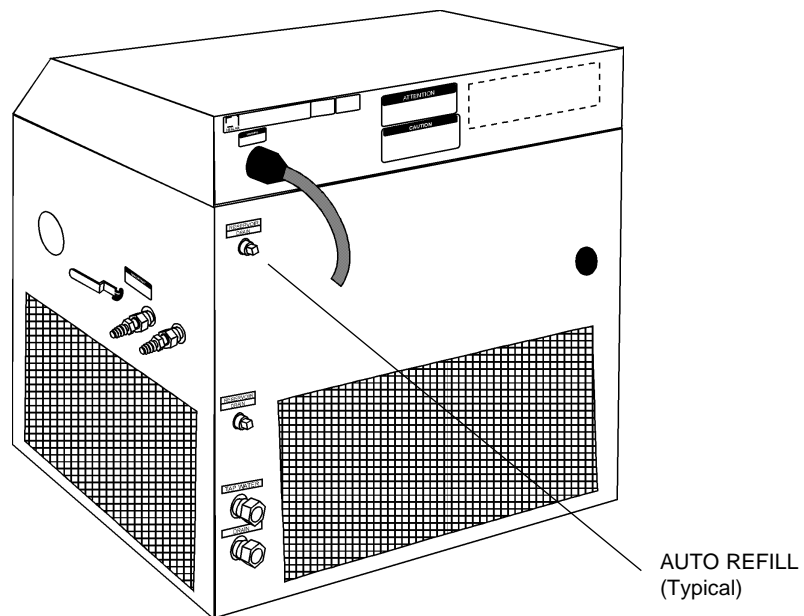

## Heater Package

The heater package option consists of an immersion heater in the unit's fluid reservoir, a high temperature limit device, and a solid state zero-crossing relay. A HTC FAULT message on the controller will light if the high temperature limit device is tripped. The high temperature limit device will disconnect power to the heater if the heater surface temperature exceeds a preset limit.

Heater Package Control Box (Typical)

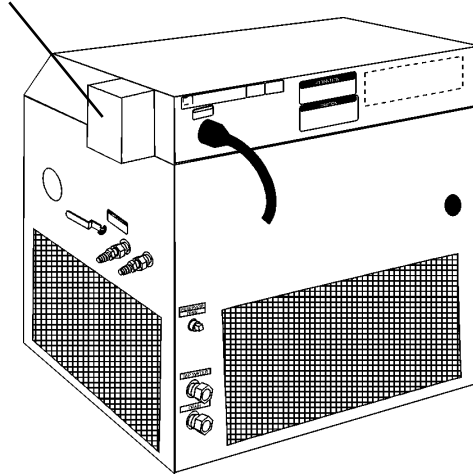

The heater surface temperature may operate several degrees higher than the reservoir fluid. The limit device is factory set to a temperature above the upper limit of the temperature controller's range.



**For personal safety and equipment reliability, the following procedure must only be performed by a qualified technician. Contact our Service Department for assistance (see Preface, After-sale Support).**

To reset a tripped temperature limit device, lift and open the case top. The case top is secured to the unit base by a hinge between the case top and the base (along the rear of the unit), and by two spring clips located at the front corners. To gain access to the temperature limit device, disengage the spring clips with a flat bladed screw driver and lift the front of the case top and tilt it back. A support brace, located on the right side of the inner case, will stop and support the case top.

You must identify and correct the fault before restarting the unit.

The protection device and the heater power connections are located in a small stainless steel box on top of the fluid reservoir. The protection device has a reset button and a temperature limit adjustment shaft. Press the reset button to restore operation.

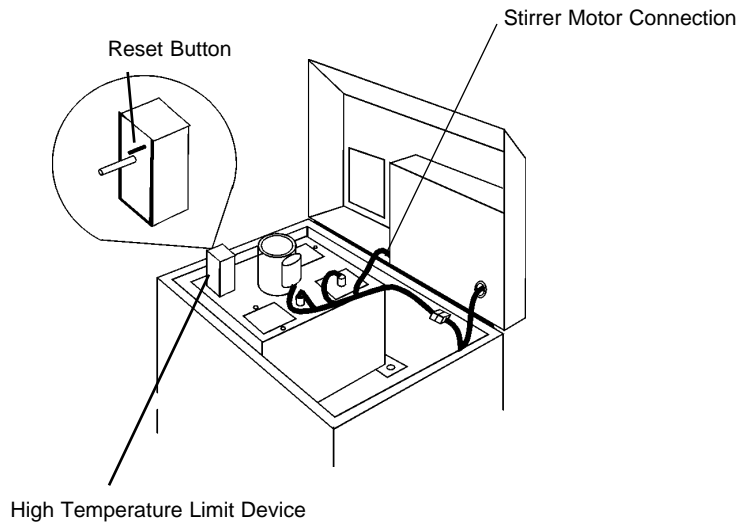

Some units equipped with heaters do not have a power cable. Installation of the cable is your responsibility. Wire the unit in conformance to local, state and federal electrical codes. Double check all wiring to make sure it is properly connected and protected from the elements.



**The unit construction provides extra protection against the risk of electric shock by grounding appropriate metal parts. The extra protection may not function unless the power cord is connected to a properly grounded outlet. It is your responsibility to assure a proper ground connection is provided. For personal safety and equipment reliability, the following procedure should only be performed by a qualified technician.**

To access the power cable connection box and install the cable:

- Lift the unit's bonnet.
- Remove the panel under the right half of the bonnet by removing the screws and the stirrer motor connection. (The stirrer motor connection is located at the lower left corner of the bonnet, see illustration above.)
- Remove the plastic plug on the rear of the bonnet. We recommend that you install an electrical conduit in place of the plastic plug.
- Insert your cable through the conduit.
- Locate the connection box and connect your cable to L1 and L2 (both connections are labeled) and to the ground stud (not labeled).
- Replace the panel and stirrer motor connection.

## External Pressure Regulator

For applications requiring a maximum pressure less than 55 psi, an External Pressure Reducer (EPR) is available. An EPR allows an adjustable operating pressure of 10 to 50 psi. If the pressure of the fluid leaving the unit exceeds the valve setting the relief valve will bypass the fluid back into the unit to relieve the pressure. The pressure of the system is determined by the back pressure of the connected equipment and the flow rate of the recirculating fluid to your application.

Connect the EPR assembly as shown below. Tighten the hose clamps tight enough to prevent leakage. Do not over-tighten or the clamps will “bite” into the flexible tubing and can cause excessive wear.

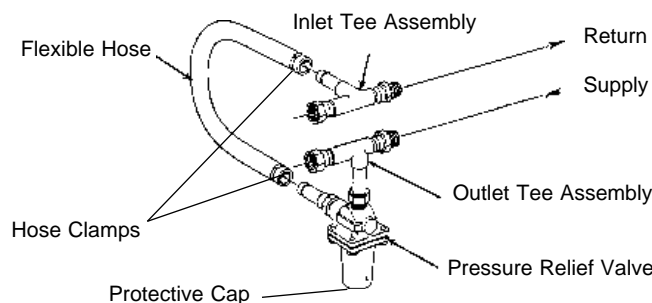

Connect the outlet tee assembly to the inlet of your application. Connect the inlet tee assembly to the outlet of your application.

### Adjustment

When adjusting the relief valve some leaking may occur, place a container under the valve during adjustment.

Remove the protective cap and locate a threaded fitting with a slot for a large screwdriver. Hold the threaded fitting in place and loosen the lock nut on the valve body until it is almost flush with the threaded fitting. Unscrew the threaded fitting three to four turns. (If the threaded fitting unscrews completely from the valve housing, screw it back in two to three turns.)

To simulate blockage, close (or pinch off) the hose between the EPR outlet tee assembly and your application. Monitor the operating pressure of the HX unit. Turn the threaded fitting until the desired relief pressure is set (the EPR valve cannot be set lower than the total back pressure of your instrument, or flow will not be received).

Tighten the locknut to secure the position of the threaded fitting. Open the hose between the EPR outlet tee assembly and your application.

## Remote Condenser

Units with the optional remote air-cooled condenser are equipped with high and low refrigeration pressure monitors. The monitors are connected internally to a pressure gauge that monitors refrigeration pressure at the suction side of the compressor. The monitors protect the refrigeration system from operating under excessively high and low refrigeration pressures. A pressure fault occurs when the refrigeration pressure exceeds the set pressure limit.

Any problem is indicated by a SYS FAULT message on the controller. In the event of either a low or high refrigeration pressure fault, the compressor will shut down. The pump and heater will continue to run. The compressor must be manually restarted after the cause of the fault has been identified and corrected.

## Nitrogen Purge

Units equipped with nitrogen purge valves are designed to accept a constant flow of dry nitrogen into the reservoir. The nitrogen blankets the cooling fluid reducing fluid evaporation.

Remove the reservoir cover by removing the screws. Fill the reservoir with fluid. Replace the reservoir cover and screws. Connect the nitrogen line to the valve on the reservoir cover.

A pressure regulator, set to 0.5 psig (0.35 kg/cm<sup>3</sup>) or lower, should be used to prevent fluid overflow.

## Particulate Filters

Some custom units are fitted with particulate filter assemblies attached to the supply side of the recirculation water. The frequency for cleaning/changing the filter depends on your usage. Should the unit's performance be degraded, check the filter.

Filters are available from NESLAB, contact our Customer Service Center. Before calling refer to the serial number label on the rear of the unit to obtain the following information:

- BOM number
- Serial number

## Section VII Maintenance

### Service Contracts

NESLAB offers on-site Service Contracts that are designed to provide extended life and minimal down-time for your unit. For more information, contact our Service Department (see Preface, After-sale Support).

### Condenser Cleaning (Air-cooled units only)

For proper operation, the unit needs to pull substantial amounts of air through a finned condenser. A build up of dust or debris on the fins of the condenser will lead to a loss of cooling capacity.

The frequency of cleaning depends on the operating environment. It is recommended that a visual inspection of the condenser be made monthly after initial installation. After several months, the frequency of cleaning will be established.

For "standard" air-cooled units, periodic vacuuming of the fins on the condenser is necessary.

For units with the optional remote air-cooled condenser, remove any debris from around the condenser site. If a visible accumulation of dust or dirt is found on the condenser fins, the condenser should be cleaned with a condenser cleaning solvent and rinsed with water.



**Exercise caution not to damage the condenser fins or coil. Condenser fin or coil damage can result in a loss of performance and, in extreme cases, refrigeration system failure.**

### Algae

To restrict the growth of algae in the fluid reservoir, it is recommended that the reservoir cover be kept in place and that all recirculation lines be opaque. This will eliminate the entrance of light which is required for the growth of most common algae.

NESLAB recommends the use of Chloramine-T, one gram per gallon.

## Section VIII Service



For personal safety and equipment reliability, the following procedure should only be performed by a qualified technician. Contact our Service Department for assistance (see Preface, After-sale Support).

### Configuration

#### Case Top

The unit has a hinged case top to allow service access. The case top is secured to the top of the unit base by a hinge between the case top and base (along the rear of the unit), and by two spring clips located at the front corners, see illustration on page 7. To gain access to the pump assembly or the reservoir area, disengage the spring clips with a flat bladed screw driver and lift the front of the top cover and tilt it back. A support brace, located on the right side of the inner base, will stop and support the case top. Ensure the spring clips engage when the top is lowered back into position.

#### Reservoir Cover

Access to the inside of the fluid reservoir is necessary to clean the reservoir. The figure below illustrates a typical layout of the components mounted on top of the reservoir cover. The component layout varies depending on the unit size. If you are unable to identify the components on your unit's reservoir cover, contact our Customer Service Department for assistance (see Preface, After-sale Support).

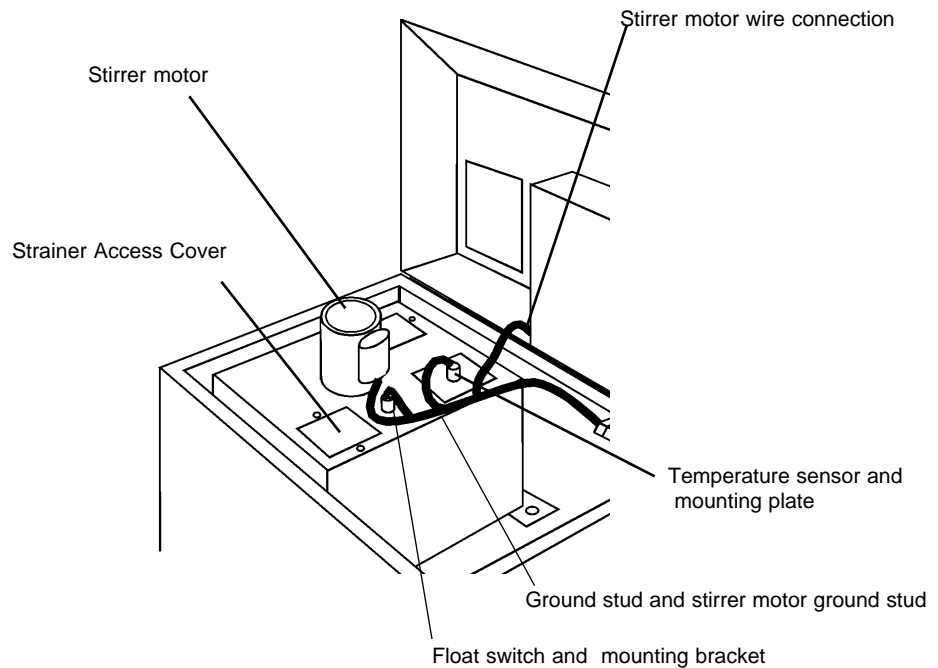

**Disconnect the unit from its power source before removing the reservoir cover.**

Locate the reservoir stirrer motor (units with plate heat exchangers and HX-75s do not have a stirrer motor; HX-500s and HX-750s have two stirrer motors). Disconnect the motor wires at the plug located on the side of the electrical box cover. Also disconnect the green ground wire that connects the ground stud on the reservoir cover to the unit's grounding bar.

Locate the float switch mounting bracket. Remove the two stainless steel screws that secure the bracket to the reservoir cover. Carefully remove the mounting bracket and place the assembly in an area adjacent to the reservoir. Make sure not to strain the connecting wires.

Locate the temperature sensor mounting plate. Remove the two stainless screws that secure the bracket to the reservoir. Carefully remove the sensor mounting plate with the sensor(s) attached and place the assembly in a protected area adjacent to the reservoir. Make sure not to damage the sensor(s) or strain the connecting wires.

Remove the stainless steel screws that secure the reservoir cover to the reservoir. Remove the cover and place it to one side in a manner that protects the stirrer motor blades from being bent.

#### **Service Access Panels**

Service access panels on your unit allow easy access to the pump and refrigeration assemblies. Panel location varies with the size and type of unit. The panels are designed to allow removal without disconnecting the HX from the instrument being cooled.



**Disconnect the unit from its power source before removing any of the access panels.**

## **Reservoir Cleaning**

Periodic reservoir cleaning is necessary. We recommend that a visual inspection of the reservoir be made monthly after initial installation. After several months, the frequency of cleaning will be established.



**Disconnect the unit from its power source and drain the reservoir before cleaning the reservoir.**

Lift the top cover to access the reservoir. Remove the reservoir cover as described in Section VIII, Configuration. Clean the reservoir with a cleaning fluid compatible with the recirculating system and the cooling fluid.



**Do not use steel wool or other abrasive materials. They can scratch the stainless steel surface and initiate rusting.**

When the reservoir is clean, re-assemble the cover assembly and close the case top. Refer to Section III, Filling Requirements for instructions on replacing the cooling fluid.

## Pump and Flow Switch Strainers

The pump and flow switch strainers require cleaning. If debris is drawn into the recirculating system, the pump strainer will prevent the material from being drawn into the pump and damaging the pump vanes and the filter strainer will prevent material from clogging the flow switch.

After initial installation, the strainers may become clogged with debris and scale. Clean the strainer after the first week of installation. After this first cleaning, a monthly visual inspection is recommended. After several months, the frequency of cleaning will be established.



**Disconnect the power cord from the power source and drain the fluid reservoir before cleaning the strainer. Do not operate the unit with any strainer removed.**

### PD-2 and TU Pumps

The wire mesh pump strainer is located in the reservoir on the pump suction line. Remove the strainer access panel located on top of the reservoir cover to access the strainer.

Cover the strainer with a plastic bag to help catch any debris which may become free.

Unscrew the strainer and rinse it with water. Replace the strainer. Refer to Section III, Filling Requirements for instructions on replacing the cooling fluid.

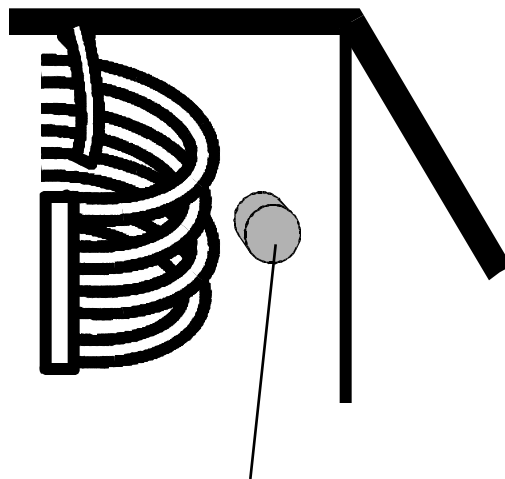

Pump Strainer

### PD-1 Pumps

The wire mesh pump strainer is located on the inlet (suction) side in the pump head.

Lift the case top and remove the top right access panel to access the pump area. Unscrew the larger of the two acorn nuts on the pump head and remove the screen. Clean the screen by rinsing it with water.

When the screen is clean, replace it in the pump head and tighten the acorn nut. Replace the access panel and close the case top.

Refer to Section III, Filling Requirements for instructions on replacing the cooling fluid.

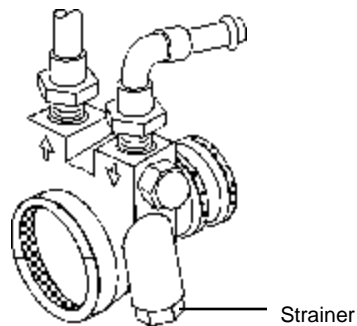

### Flow Filter Strainer

The flow filter strainer is located behind the top right access panel on the inlet side of the flow switch.

Unscrew the locknut and remove the screen. Clean the screen by rinsing it with water.

Replace the strainer and locknut. Refer to Section III, Filling Requirements for instructions on replacing the cooling fluid.

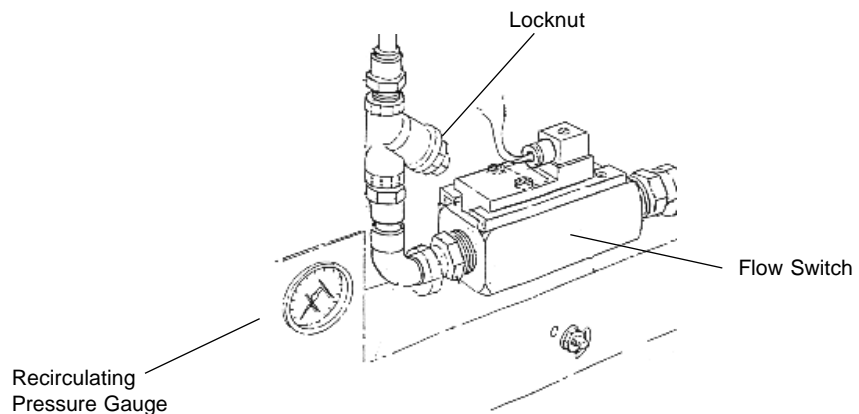

## Pump Motor Lubrication

Units with PD-1 and PD-2 pumps require pump motor lubrication. Refer to the pump identification label on the rear of the case top to identify the specific pump in your unit.

Motors used to drive the pump are manufactured by several companies. These motors use sleeve type bearings with large oil reservoirs. Oiling instructions are generally posted on each motor. In the absence of instructions, add approximately 30 to 35 drops of SAE 20 non-detergent oil in each fill hole on the following schedule (SAE 20 = 142 CS viscosity):

Duty Cycle	Oiling Frequency
Continuous	Once every year
Intermittent	Once every 2 years
Occasional	Once every 5 years

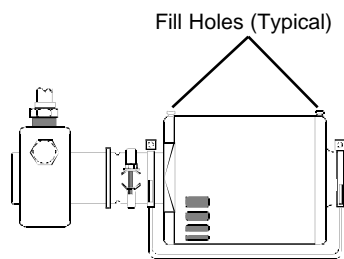

## Phase Rotation

Three phase units with three phase pump motors are equipped with a phase rotation interlock. Refer to the serial number label on the rear of the case top for the specific electrical requirements of your unit. The interlock prevents the unit from starting if the phase rotation is wrong. If the unit will not start, see Section IX, Checklist. If the options in the checklist are not applicable, the problem may be phase rotation.

Disconnect the unit from its power source, remove the rear panel and the junction box cover (if so equipped). Reverse any two line conductors on the line side of the relay.



**Never remove the green ground wire.**

Replace the junction box and the rear panel. Reconnect the unit to its power source. If the unit will not start, contact our Customer Service Department.

**Suction Discharge  
Pressue  
Speed Check (R-22)**

<b>Air-Cooled Standard and High Temperature Units (All Pump Types)<sup>1</sup></b>			
Unit	Suction(psi)	Discharge(psi)	Speed Check(°C/Minute)
HX-75	77 - 84	225 - 250	1.5 - 1.7
HX-100	75 - 83	245 - 265	1.3 - 1.6
HX-150	70 - 73	240 - 270	2.0 - 2.5
HX-200	85 - 105	230 - 255	1.6 - 1.9
HX-300	84 - 105	270 - 305	2.4 - 2.7
HX-500	80 - 90	215 - 235	2.0 - 2.4
HX-750	65 - 75	185 - 215	

<b>Water-Cooled Standard and High Temperature Units (All Pump Types)<sup>2</sup></b>		
Unit	Suction(psi)	Discharge(psi)
HX-75	72	170
HX-100	86 - 92	180
HX-150	65	175
HX-200	85 - 90	180
HX-300	73 - 78	180
HX-500	75 - 82	150
HX-750	50 - 60	180

1. 27°C unit temperature, water in reservoir, access panel removed.  
 2. 25°C unit temperature, water in reservoir.

**NOTE:** Refrigerant R-22. For low temperature units please call NESLAB.

## Section IX Troubleshooting

### Checklist

#### Unit will not start

For CE Mark units, check the circuit breaker setting on the rear of the bonnet.

Check power source for correct voltage output. Refer to the serial number label on the rear of the unit for the specific electrical requirements of your unit. Power source must be specified voltage,  $\pm 10\%$ .

Check house circuit breaker.

On three phase units with three phase pump motors, the phase rotation may be reversed (see Section VIII, Phase Rotation).

On water-cooled units, ensure the facility water is on and make sure the cooling water supply is connected to the TAP WATER connection, not the DRAIN connection. Check the High Pressure Cutout, it may need to be reset (see Section V, Operation).

#### Unit will not circulate fluid

Check the tubing, flow switch strainer, and any optional filters/cartridges between the unit and your application for obstructions or for cleaning/replacement.

Units with PD and TU type pumps may require pump strainer cleaning. Refer to the pump identification label on the rear of the case top to identify the specific pump in your unit. For instructions on cleaning the pump strainer, see Section VIII, Pump Strainer.

On units with CP type pumps, if the back pressure of the instrument being cooled is greater than the maximum pressure of the pump, adequate flow may not be obtained. Check for obstructions in the tubing.

#### Inadequate temperature control

Make sure the installation of the unit is in compliance with the conditions described in Section III.

Make sure the heat load of the instrument being cooled is not greater than the cooling capacity of the unit.

When the unit is shut off, wait approximately five minutes before restarting. This allows time for the refrigeration pressures to equalize. If the pressures are not allowed to equalize, the compressor will short-cycle (clicking sound) and no cooling will occur.

### Service Assistance

If, after following these troubleshooting steps, your unit fails to operate properly, contact our Service Department for assistance (see Preface, After-sale Support). Before calling, please obtain the following information:

- *BOM number*
- *Serial number*

## Section X Diagrams

**Refrigeration  
Flow Diagram  
(HX-75 through HX-150)**

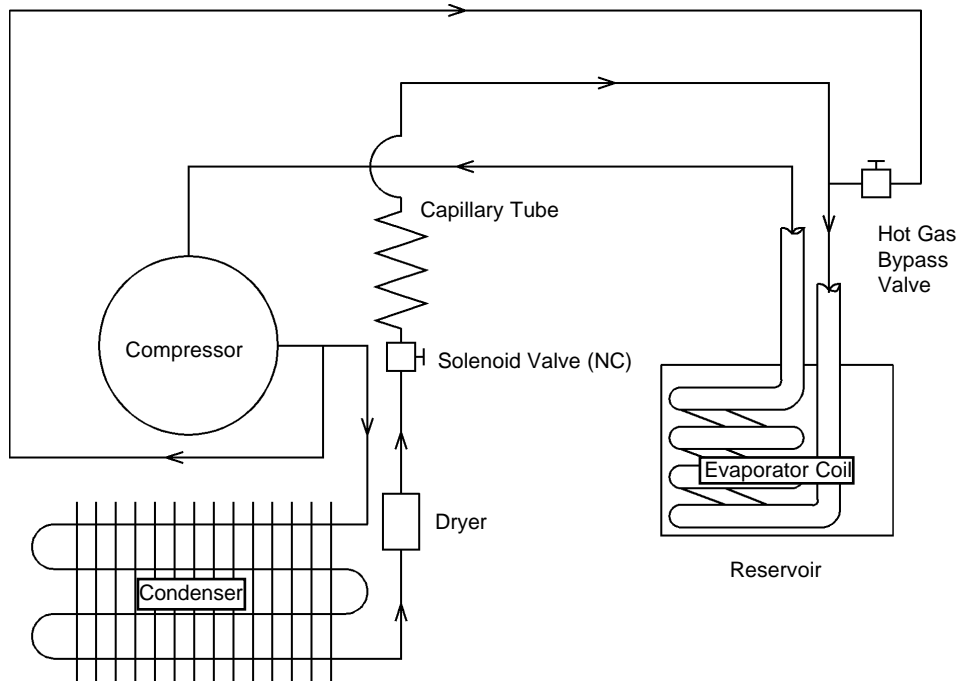

**Refrigeration  
Flow Diagram  
(HX-200 through HX-750)**

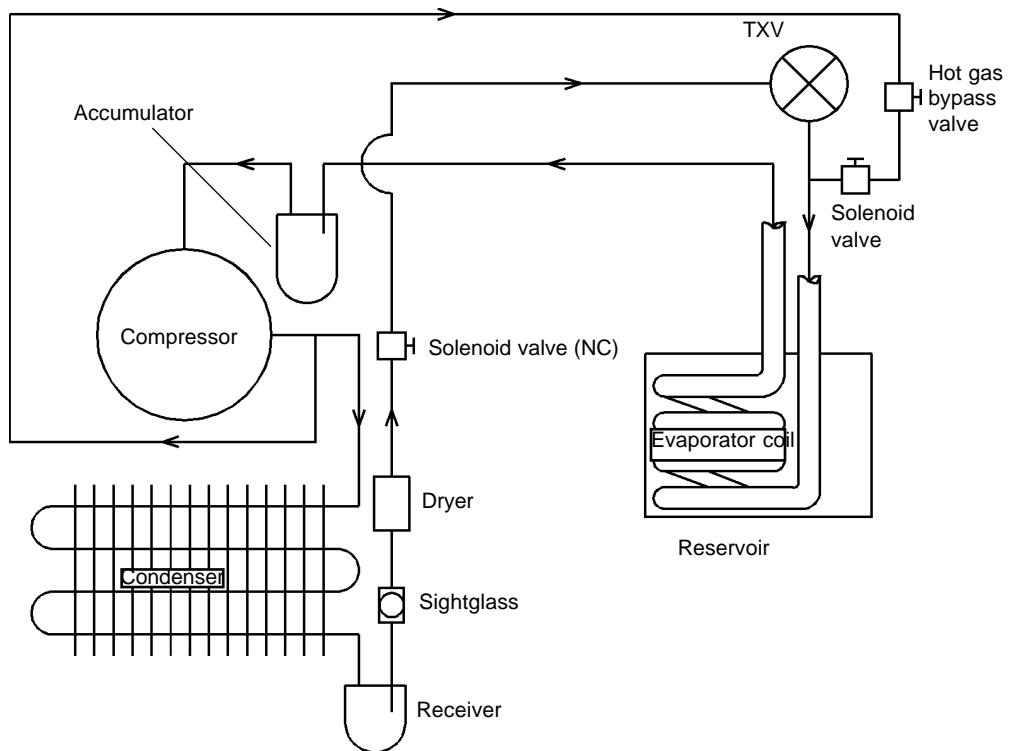

**Pump Flow Diagram (CP Pumps)**

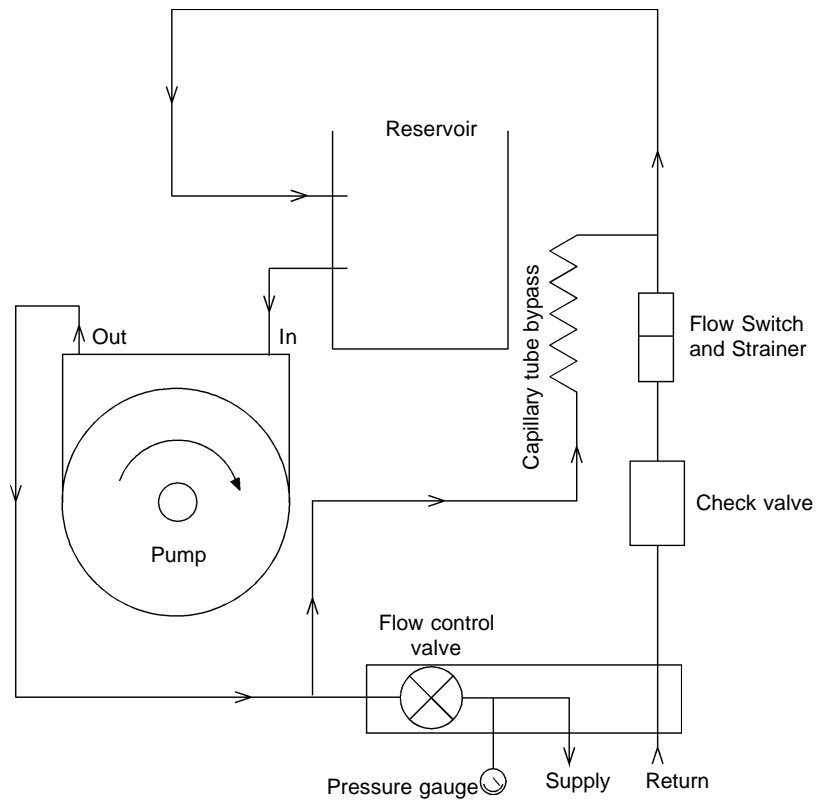

**Pump Flow Diagram (PD and TU Pumps)**

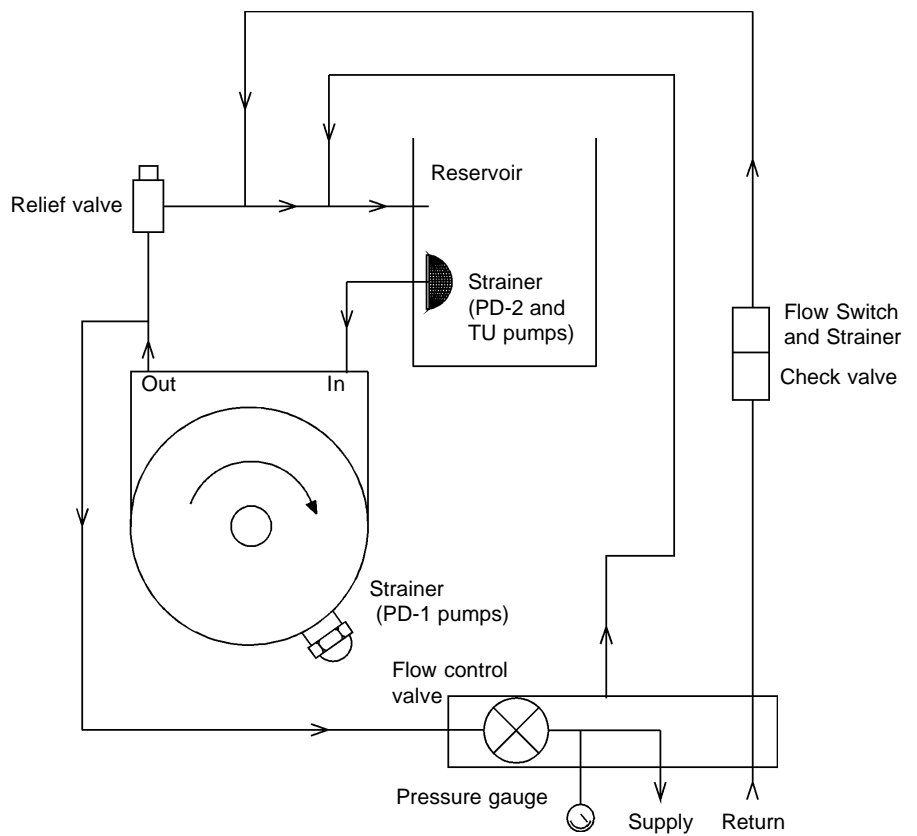

## Dimensions

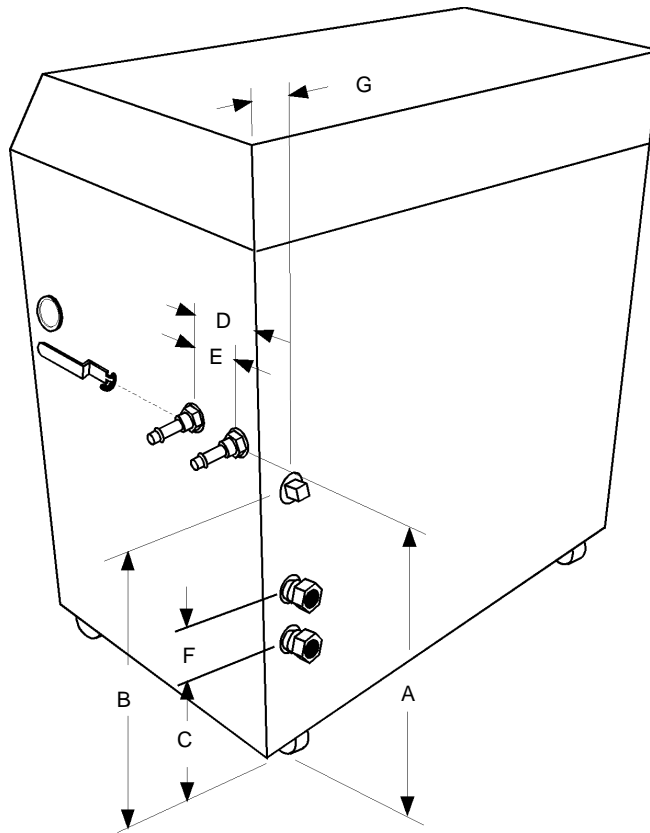

	HX75	HX100/HX150	HX200/HX300	HX500/HX900WC	HX750*/HX900AC
Unit Dimensions					
<i>Dimension A</i>	16	20	25 3/8	25 1/4	41
<i>Dimension B</i>	15 1/4	19 1/4	23 1/2	21 1/8	33 3/4
<i>Dimension C</i>	8 1/4	9 1/4	8 3/8	5 1/2	NA
<i>Dimension D</i>	7 1/4		7 1/2		9 1/2
<i>Dimension E</i>				3	
<i>Dimension F</i>	3		3	5 1/2	NA
<i>Dimension G</i>	1 3/8		1 1/2	2 1/4	NA
<i>Dimension H</i>	2 1/2		2 3/8		2 1/4
<i>Dimension I</i>	25 7/8	28 1/2	32 1/2	36 1/8	36
<i>Dimension J</i>	48 1/2	54	64 7/8	73 1/2	86 1/4
Crate Dimensions (H x W x D)	46x30x27	49x33x29	55x40x33	61x54x36	74x54x36

\* HX-750 air-cooled units. HX-750 water-cooled are the same size as the HX-500 units.

1. Dimensions are given in inches, ±1/8 inch.
2. Model HX-750 with a water-cooled condenser has the same dimensions as an HX-500.
4. Dimension A is the distance from the floor to the center of the SUPPLY and RETURN connections.
5. Dimension B is the distance from the floor to the center of the DRAIN connection.
6. Dimension C is the distance from the floor to the center of the tap water outlet connection.
7. Dimension D is the distance from the center of the SUPPLY connection to the rear of the unit case.
8. Dimension E is the distance between the SUPPLY and RETURN connections.
9. Dimension F is the distance between the center of the TAP WATER connections (upper inlet and lower outlet).
10. Dimension G is the distance from the edge of the unit case to the center of the three plumbing connections.
11. Dimension H is the distance from the floor to the bottom of the case, height of the castors (not shown).
12. Dimension I is the depth of the unit with the case top open (not shown).
13. Dimension J is the height of the unit with the case top open (not shown).

## Appendix A Standard Analog Interface J-100

Pin#	Alarm Circuitry	Control Circuitry	Definitions
1	Chassis Ground	Chassis Ground	Chassis Ground
2		Analog Ground	Electrical Ground
3	Low Level		Dry Contact
4	Warn		Dry Contact
5	System (Pump) On		Dry Contact
6		Resistivity Out	Selectable Scale 0-10VDC or 10mV/°C
7		Sensor Temperature Out	Selectable Scale 0-10VDC or 10mV/°C
8	Low Flow		Dry Contact
9	Horn (Optional)/Fault		Optional Buzzer
10	NA	NA	
11	NA	NA	
12	NA	NA	
13	NA	NA	
14	NA	NA	
15		Remote Setpoint In	Selectable Scale 0-10VDC or 10mV/°C

Low Level Fault - a dry contact in the Normally Open position, the contact closes when the controller detects a low level fault.

Low Flow Fault - a dry contact in the Normally Open position, the contact closes when the controller detects a low flow fault.

Overrange/Resistivity - a dry contact in the Normally Open position, the contact closes when the controller detects a high temperature warning or fault, low temperature warning or fault, overrange/resistivity, system fault or high temperature cutout fault.

System On - a dry contact in the Normally Open position, the contact closes when the system is operational.

Horn (Optional) Fault - a dry contact in the Normally Open position, the optional horn sounds and/or the contact closes when the controller detects a low flow fault, level fault, overrange/resistivity, system fault or high temperature cutout fault.

Resistivity Out - scale is 0.5VDC/M-cm.

Reservoir Temperature Out - customer specified scale of either 1-10VDC or 10mV/°C.

Remote Setpoint In - customer specified scale of either 1-10VDC or 10mV/°C.

## Appendix B Programming Software

### NEScom Software

The NESLAB Communications Software is a user friendly software that allows you to automate your temperature control process. The software includes a 3½" disk, Comprehensive Operator's Manual and a toll-free number to a trained technical staff.

NEScom Software allows you to write custom temperature programs for our Digital or Microprocessor based temperature control apparatus. Choose upper or lower temperature limits and monitor system status with an alarm. NEScom can also record your results on a user selectable graph. NesCom must be used with an IBM or 100% compatible computer.

Select from easy to use product icons.

Create graphs and charts.

Easily configure ramping functions which set the setpoint over time.

View pop-up alarm windows which display if an alarm condition occurred.

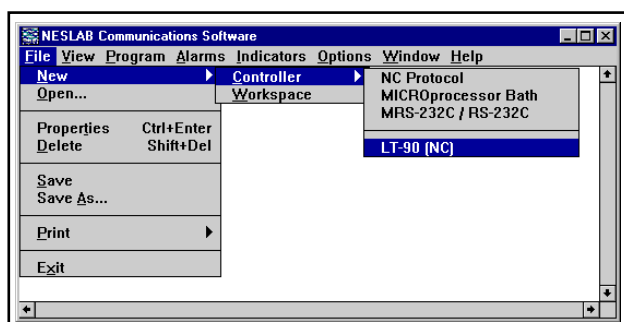

Select software functions from the easy to use pulldown menus.



View a virtual controller screen which allows remote monitoring and operation of product control panel.

## DeltaTemp

DeltaTemp programming software is now available for free download from NESLAB ONLINE BBS (Bulletin Board System) at 603-427-2490.

DeltaTemp software allows you to write custom temperature programs for NESLAB digital units (any unit with a digital temperature readout AND a 10-15 pin INTERFACE port). The menu-driven program provides a table format for entering temperature parameters and a visual graph confirmation of the program you have designed. Program time can range from 0 to 999 minutes with unlimited looping. Choose upper and lower temperature limits and monitor system status with an audible alarm. DeltaTemp can also record your results on a printed graph or file. DeltaTemp is a DOS program, and requires an IBM or 100% compatible computer.

DeltaTemp may require use of a computer interface device, depending on which NESLAB unit is being used. Refer to the setup diagram in the DeltaTemp folder for full details.

To download the software, go to: CONFERENCES / SOFTWARE / DeltaTemp.

The folder also contains the operating manual, setup diagrams, application notes, and directions on making your own interface cable.

NESLAB ONLINE is a FirstClass® system accessible by general terminal software (Windows Terminal accessory, ClarisWorks Communications, Z-Term, Pro-Comm, or similar).

To use the full graphics and features of the BBS we recommend using FirstClass® Client software. FirstClass® Client is available for Macintosh or Windows platforms. It is available from many sources:

### NESLAB ONLINE

Mac: Conferences/Software/Macintosh

Windows: Conferences/Software/Windows

### AMERICA ONLINE

Mac: Computing/software center/mac communications forum/industry connection/softarc

Windows: Computing/software center/communications programs

### COMPUSERVE:

Mac: TWEUROPA/Teletools/FCMAC.ZIP

Windows: PCBBS/BBS programs/FC300.EXE

### WORLD WIDE WEB

<http://www.softarc.com/try.htm>

## WARRANTY

NESLAB Instruments, Inc. warrants for 12 months from date of shipment any NESLAB unit according to the following terms.

Any part of the unit manufactured or supplied by NESLAB and found in the reasonable judgment of NESLAB to be defective in material or workmanship will be repaired at an authorized NESLAB Repair Depot without charge for parts or labor. The unit, including any defective part must be returned to an authorized NESLAB Repair Depot within the warranty period. The expense of returning the unit to the authorized NESLAB Repair Depot for warranty service will be paid for by the buyer. NESLAB's responsibility in respect to warranty claims is limited to performing the required repairs or replacements, and no claim of breach of warranty shall be cause for cancellation or rescission of the contract of sales of any unit.

With respect to units that qualify for field service repairs, NESLAB's responsibility is limited to the component parts necessary for the repair and the labor that is required on site to perform the repair. Any travel labor or mileage charges are the financial responsibility of the buyer.

The buyer shall be responsible for any evaluation or warranty service call (including labor charges) if no defects are found with the NESLAB product.

This warranty does not cover any unit that has been subject to misuse, neglect, or accident. This warranty does not apply to any damage to the unit that is the result of improper installation or maintenance, or to any unit that has been operated or maintained in any way contrary to the operating or maintenance instructions specified in NESLAB's Instruction and Operation Manual. This warranty does not cover any unit that has been altered or modified so as to change its intended use.

In addition, this warranty does not extend to repairs made by the use of parts, accessories, or fluids which are either incompatible with the unit or adversely affect its operation, performance, or durability.

NESLAB reserves the right to change or improve the design of any unit without assuming any obligation to modify any unit previously manufactured.

THE FOREGOING EXPRESS WARRANTY IS IN LIEU OF ALL OTHER WARRANTIES, EXPRESSED OR IMPLIED, INCLUDING BUT NOT LIMITED TO WARRANTIES OR MERCHANTABILITY AND FITNESS FOR A PARTICULAR PURPOSE.

NESLAB'S OBLIGATION UNDER THIS WARRANTY IS STRICTLY AND EXCLUSIVELY LIMITED TO THE REPAIR OR REPLACEMENT OF DEFECTIVE COMPONENT PARTS AND NESLAB DOES NOT ASSUME OR AUTHORIZE ANYONE TO ASSUME FOR IT ANY OTHER OBLIGATION.

NESLAB ASSUMES NO RESPONSIBILITY FOR INCIDENTAL, CONSEQUENTIAL, OR OTHER DAMAGES INCLUDING, BUT NOT LIMITED TO LOSS OR DAMAGE TO PROPERTY, LOSS OF PROFITS OR REVENUE, LOSS OF THE UNIT, LOSS OF TIME, OR INCONVENIENCE.

This warranty applies to units sold in the United States. Any units sold elsewhere are warranted by the affiliated marketing company of NESLAB Instruments, Inc. This warranty and all matters arising pursuant to it shall be governed by the law of the State of New Hampshire, United States. All legal actions brought in relation hereto shall be filed in the appropriate state or federal courts in New Hampshire, unless waived by NESLAB.