

## WARRANTY

NESLAB Instruments, Inc. warrants for 12 months from date of shipment any NESLAB unit according to the following terms.

Any part of the unit manufactured or supplied by NESLAB and found in the reasonable judgment of NESLAB to be defective in material or workmanship will be repaired at an authorized NESLAB Repair Depot without charge for parts or labor. The unit, including any defective part must be returned to an authorized NESLAB Repair Depot within the warranty period. The expense of returning the unit to the authorized NESLAB Repair Depot for warranty service will be paid for by the buyer. NESLAB's responsibility in respect to warranty claims is limited to performing the required repairs or replacements, and no claim of breach of warranty shall be cause for cancellation or rescission of the contract of sales of any unit. With respect to units that qualify for field service repairs, NESLAB's responsibility is limited to the component parts necessary for the repair and the labor that is required on site to perform the repair. Any travel labor or mileage charges are the financial responsibility of the buyer.

The buyer shall be responsible for any evaluation or warranty service call (including labor charges) if no defects are found with the NESLAB product.

This warranty does not cover any unit that has been subject to misuse, neglect, or accident. This warranty does not apply to any damage to the unit that is the result of improper installation or maintenance, or to any unit that has been operated or maintained in any way contrary to the operating or maintenance instructions specified in NESLAB's Instruction and Operation Manual. This warranty does not cover any unit that has been altered or modified so as to change its intended use.

In addition, this warranty does not extend to repairs made by the use of parts, accessories, or fluids which are either incompatible with the unit or adversely affect its operation, performance, or durability.

NESLAB reserves the right to change or improve the design of any unit without assuming any obligation to modify any unit previously manufactured.

THE FOREGOING EXPRESS WARRANTY IS IN LIEU OF ALL OTHER WARRANTIES, EXPRESSED OR IMPLIED, INCLUDING BUT NOT LIMITED TO WARRANTIES OR MERCHANTABILITY AND FITNESS FOR A PARTICULAR PURPOSE.

NESLAB'S OBLIGATION UNDER THIS WARRANTY IS STRICTLY AND EXCLUSIVELY LIMITED TO THE REPAIR OR REPLACEMENT OF DEFECTIVE COMPONENT PARTS AND NESLAB DOES NOT ASSUME OR AUTHORIZE ANYONE TO ASSUME FOR IT ANY OTHER OBLIGATION.

NESLAB ASSUMES NO RESPONSIBILITY FOR INCIDENTAL, CONSEQUENTIAL, OR OTHER DAMAGES INCLUDING, BUT NOT LIMITED TO LOSS OR DAMAGE TO PROPERTY, LOSS OF PROFITS OR REVENUE, LOSS OF THE UNIT, LOSS OF TIME, OR INCONVENIENCE.

This warranty applies to units sold in the United States. Any units sold elsewhere are warranted by the affiliated marketing company of NESLAB Instruments, Inc. This warranty and all matters arising pursuant to it shall be governed by the law of the State of New Hampshire, United States. All legal actions brought in relation hereto shall be filed in the appropriate state or federal courts in New Hampshire, unless waived by NESLAB.

# RTE-Series Refrigerated Bath/Circulator

## Table of Contents

<b>PREFACE</b>	
	Compliance ..... 2
	Unpacking ..... 2
	Warranty ..... 2
	After-sale Support ..... 2
<b>SECTION I</b>	
<b>Safety</b>	
	Warnings ..... 3
<b>SECTION II</b>	
<b>General Information</b>	
	Description ..... 4
	Specifications ..... 4
<b>SECTION III</b>	
<b>Installation</b>	
	Site ..... 5
	Electrical Requirements ..... 5
	Plumbing Requirements ..... 6
	Fluids ..... 8
	Filling Requirements ..... 8
	Water Quality Standards and Recommendations ..... 9
<b>SECTION IV</b>	
<b>Temperature Controller</b>	
	Start Up ..... 10
	Controller Keypad & Display ..... 10
	Changing a Value ..... 11
	Controller Displays ..... 11
	Operator's Loop ..... 12
	Setup Loop ..... 13
	Error Messages ..... 15
	Autorefill (Optional) ..... 16
	High Temperature/Low Liquid Level Safety ..... 17
	9-Pin Accessory Connectors ..... 18
<b>SECTION V</b>	
<b>Maintenance</b>	
	Service Contracts ..... 19
	Condenser ..... 19
	Reservoir Cleaning ..... 20
	Algae ..... 20
	Additional Loops ..... 21
	Calibration Loop ..... 22
	Calibration Procedure ..... 22
<b>SECTION VI</b>	
<b>Troubleshooting</b>	
	Checklist ..... 24
	Service Assistance and Technical Support ..... 24
<b>SECTION VII</b>	
<b>Programming Software/ RS232 Communication</b>	..... 25
<b>WARRANTY</b>	

## Preface

### Compliance

Products tested and found to be in compliance with the requirements defined in the EMC standards defined by 89/336/EEC as well as Low Voltage Directive (LVD) 73/23/EEC can be identified by the CE label on the rear of the unit. The testing has demonstrated compliance with the following directives:

LVD, 73/23/EEC	Complies with UL 3101-1:93
EMC, 89/336/EEC	EN 55011, Class A Verification EN 50082-1:1992 IEC 1000-4-2:1995 IEC 1000-4-3:1994 IEC 1000-4-4:1995

For any additional information refer to the Letter of Compliance that shipped with the unit (Declaration of Conformity).

### Unpacking

Retain all cartons and packing material until the unit is operated and found to be in good condition. If the unit shows external or internal damage, or does not operate properly, contact the transportation company and file a damage claim. Under ICC regulations, this is your responsibility.

### Warranty

Units have a warranty against defective parts and workmanship for one year from date of shipment. See back page for more details.

### After-sale Support

NESLAB is committed to customer service both during and after the sale. If you have questions concerning the operation of your unit, contact our Sales Department. If your unit fails to operate properly, or if you have questions concerning spare parts or Service Contracts, contact our Customer Service Department. Before calling, please obtain the following information from the unit's serial number label:

- *BOM number* \_\_\_\_\_
- *Serial number* \_\_\_\_\_

## Section I Safety

### Warnings

Make sure you read and understand all instructions and safety precautions listed in this manual before installing or operating your unit. If you have any questions concerning the operation of your unit or the information in this manual, contact our Sales Department.

**Performance of installation, operation, or maintenance procedures other than those described in this manual may result in a hazardous situation and may void the manufacturer's warranty.**

**Transport the unit with care. Sudden jolts or drops can damage the refrigeration lines. The units weigh approximately: RTE-111, 86 pounds (390 kilograms); RTE-211, 99 pounds (45 kilograms); RTE-221, 106 pounds (48 kilograms). Units should be transported with equipment designed to lift these weights.**

**Observe all warning labels.**

**Never remove warning labels.**

**Never operate damaged or leaking equipment.**

**Never operate the unit without bath fluid in the bath.**

**Never use pure ethylene glycol as a bath fluid. Above 80°C the user is responsible for the fluid used.**

**For 220 - 240 volt units supplied without a line cord, use a harmonized (HAR) grounded 3-conductor cord, type H 0 5 V V - F , with conductors listed below. A suitable cord end is required for connecting to the equipment (see unit socket) and must terminate with an IEC approved plug for proper connection to power supply.**

RTE-111 and RTE-211	Nominal 1.0 mm <sup>2</sup> cross section rated 10 Amps Unit Socket: IEC - 320 C13
RTE-221	Nominal 1.5 mm <sup>2</sup> cross section rated 16 Amps Unit Socket: IEC - 320 C19

**Always turn off the unit and disconnect the line cord from the power source before performing any service or maintenance procedures, or before moving the unit.**

**Always empty the bath before moving the unit.**

**Never operate equipment with damaged line cords.**

**Refer service and repairs to a qualified technician.**

In addition to the safety warnings listed above, warnings are posted throughout the manual. These warnings are designated by an exclamation mark inside an equilateral triangle with text highlighted in bold print. Read and follow these important instructions. Failure to observe these instructions can result in permanent damage to the unit, significant property damage, personal injury or death.

## Section II General Information

### Description

The RTE-Series Refrigerated Bath/Circulators are designed to provide temperature control for applications requiring a fluid work area or pumping to an external system.

Units consists of a non-CFC air-cooled refrigeration system, circulation pump, seamless stainless steel bath, work area cover, and a temperature controller.

<b>Specifications</b>	<b>RTE-111</b>	<b>RTE-211</b>	<b>RTE-221</b>
<b>Temperature Range<sup>1</sup></b>	-25°C to +150°C		-23°C to +150°C
<b>Temperature Stability<sup>2,3,4</sup></b>	±0.01°C		
<b>Cooling Capacity<sup>2,5</sup></b> <i>Watts</i> <i>BTU/H</i>	500 1705		
<b>Pump Capacity</b>	15 lpm at 0' (0 M) 0 lpm at 16' (4.9 M)		
<b>Heater (Watts)</b> <i>60 Hz Models</i> <i>50 Hz Models</i>	800 1000	800 1000	1600 1800
<b>Bath Work Area</b> <i>(L x W x D)</i> <i>Inches</i> <i>Centimeters</i>	4 3/4 x 8 x 6 12.1 x 20.3 x 15.3	9 1/4 x 10 x 6 23.5 x 25.4 x 15.2	9 1/4 x 10 x 9 23.5 x 25.4 x 22.9
<b>Bath Volume</b> <i>Gallons/Liters</i>	1.9/7.0	3.2/12.25	5.4/20.5
<b>Case Dimensions</b> <i>(H x W x D)</i> <i>Inches</i> <i>Centimeters</i>	25 x 10 5/16 x 15 7/8 63.5 x 26.2 x 40.3	25 x 12 3/8 x 18 3/8 63.5 x 31.4 x 46.7	27 7/8 x 12 3/8 x 18 3/8 70.8 x 31.4 x 46.7
<b>Power Requirements<sup>6</sup></b>	115 V, 60 Hz 220/240 V, 50 Hz		

1. Low end temperature for 50Hz units is -18°C, -23°C and -21°C respectively.
2. Specifications listed for units operating at +20°C bath temperature, +20°C (+70°F) ambient, with tap water as bath fluid.
3. For operation below 0°C, covering the bath work area may improve stability.
4. For some applications, agitation and stability above ambient may be improved by connecting a small length of hose between the pump connections on the rear of the unit.
5. 50 Hz RTE-111 units have a 375 watt cooling capacity.
6. Control transformer fusing - 115VAC units = (T=Time Delay) 500mA 250V 5 x 20mm (Qty 1), 220VAC units = [T=Time Delay] 250mA 250V to 5 x 20mm (Qty 2).  
Bussman fusing part numbers: 500mA fuse = Bussman S504-500mA  
250mA fuse = Bussman S504-250mA

## Section III Installation

### Site

The indentations on the unit's sides are designed to function as handles. Lift the unit by the handles and locate it on a sturdy work area. Ambient temperatures should be inside the range of +50°F to +80°F (+10°C to +27°C).



**Never place the unit in a location where excessive heat, moisture, or corrosive materials are present.**

The unit has an air-cooled refrigeration system. Air is drawn through the front panel and discharged through the rear panel. The unit must be positioned so the air intake and discharge are not impeded. A minimum clearance of 12 inches (30 centimeters) at the front and rear of the unit is necessary for adequate ventilation. Inadequate ventilation will reduce cooling capacity and, in extreme cases, can cause compressor failure.

Excessively dusty areas should be avoided and a periodic cleaning schedule should be instituted (see Section VI, Cleaning).

The unit will retain its full rated capacity in ambient temperatures up to approximately +75°F (+24°C). Above +75°F, derate the cooling capacity 1% for every 1°F above +75°F, to a maximum ambient temperature of +95°F. In terms of Celsius, derate the cooling capacity 1% for every 0.5°C above +24°C, to a maximum ambient temperature of +35°C.

### Electrical Requirements



**Line voltage may be easily accessible inside the pump/control box. Always unplug the unit prior to removing pump/control box cover.**

Refer to the serial number label on the rear of the unit to identify the specific electrical requirements of your unit.

Ensure the voltage of the power source meets the specified voltage,  $\pm 10\%$ .

The unit construction provides extra protection against the risk of electric shock by grounding appropriate metal parts. The extra protection may not function unless the power cord is connected to a properly grounded outlet. It is the user's responsibility to assure a proper ground connection is provided.



**For 220 - 240 volt units supplied without a line cord, use a harmonized (HAR) grounded 3-conductor cord, type H 0 5 V V - F , with conductors listed below. A suitable cord end is required for connecting to the equipment (see unit socket) and must terminate with an IEC approved plug for proper connection to power supply.**

RTE-111 and RTE-211

Nominal 1.5 mm<sup>2</sup> cross section rated 16 Amps  
Unit Socket: IEC - 320 C19

RTE-221

Nominal 1.0 mm<sup>2</sup> cross section rated 10 Amps  
Unit Socket: IEC - 320 C13

## Plumbing Requirements



**Ensure the unit is off before connecting tubing to the unit.**

### Hose Connections

The pump connections are located at the rear of the pump box and are labelled PUMP INLET and PUMP OUTLET. These connections are bent upward so the recirculating fluid will drain back into the reservoir when the hoses are disconnected. Both connections are capped with stainless steel serrated plugs.

The pump lines have ¼" MPT for mating with standard plumbing fittings. For your convenience stainless steel adapters, ¼" FPT to ¾" O.D. serrated fitting, are provided. (To assure proper fit, they should be installed using 1½ turns of Teflon® tape around the threads.)

Flexible tubing, if used, should be of heavy wall or reinforced construction. Make sure all tubing connections are securely clamped. Avoid running tubing near radiators, hot water pipes, etc. If substantial lengths of tubing are necessary, insulation may be required to prevent loss of cooling capacity.

Tubing and insulation are available from NESLAB. Contact our Sales Department for more information (see Preface, After-sale Support).

It is important to keep the distance between the unit and the external system as short as possible, and to use the largest diameter tubing practical. Tubing should be straight and without bends. If diameter reductions must be made, make them at the inlet and outlet of the external system, not at the unit.

If substantial lengths of cooling lines are required, they should be pre-filled with bath fluid before connecting them to the unit. This will ensure that an adequate amount of fluid will be in the bath once it is in operation.

### Pumping

The pump is designed to deliver a flow of 15 liters per minute (4 gallons per minute) at 0 feet head. To prevent external circulation, the PUMP INLET and PUMP OUTLET lines on the rear of the unit are capped. The caps must be removed when external circulation is required.

To properly secure external hose connections to the unit, wrap Teflon® tape around the pipe line threads before installation. Once the hose connections are made, the hoses must be properly plumbed to an external system. *It is important the bath is not in operation until all plumbing is complete.*

**NOTE:** To increase agitation in the bath when not circulating externally, connect a short loop of hose between the inlet and outlet lines.

If the bath is not used for external circulation or increased agitation, make sure the stainless steel caps are in place prior to operating the bath.

### Circulating to an open container

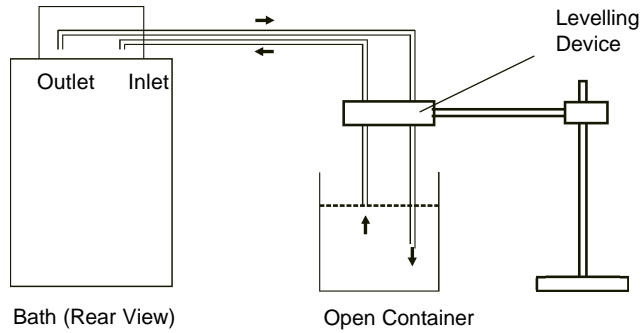

A stainless steel leveling device is available to aid circulation to an open vessel. Contact our Sales Department for more information (see Preface).

Support the leveling device over the open container with a ringstand. Stagger the tubes in the leveling device so one tube is submerged in the vessel fluid, and the other tube is level with the fluid surface. Connect the deeper tube to the PUMP OUTLET and the shorter tube to the PUMP INLET.

Adjust the flow rate using the accessory flow control valve connected to the PUMP OUTLET, or by partially restricting the outlet tubing. When properly adjusted, the pump inlet will draw an occasional air bubble to prevent over flow, and the pump outlet will force fluid through the submerged tube to prevent aeration of the vessel.

To avoid siphoning the bath work area when the unit is shut off, lift the leveling device out of the vessel and above the level of the unit.

### Circulating through two closed loops

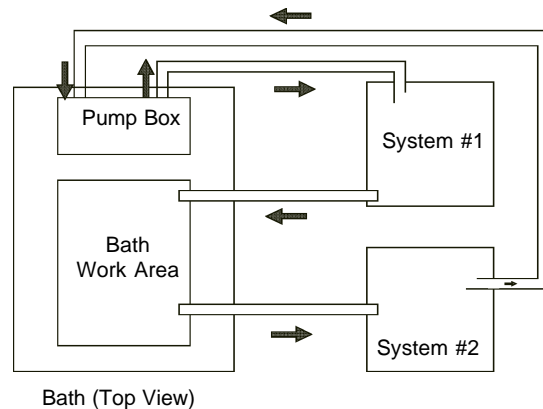

The pump can be used to circulate through two closed loop systems. Connect the shortest practical length of flexible tubing from the PUMP OUTLET to the inlet of external system #1. Connect the outlet of system #1 directly into the bath work area. Connect tubing from the bath work area to the inlet of system #2. Connect the outlet of system #2 to the PUMP INLET.

## Drain



**Ensure the temperature of the bath fluid is safe before draining the unit.**

The unit is equipped with a drain located at the back of the unit at the base of the bath. The drain has ¼" MPT and is capped with a stainless steel plug. To drain the reservoir simply remove the cap.

To assure proper fit when replacing the cap, be sure to line the threads with 1½ turns of Teflon® tape.

## Fluids



**Never use flammable or corrosive fluids with this unit.**

The selected fluid must have a viscosity of 50 centistokes or less at the lowest operating temperature.

Filtered tap water is the recommended fluid for operation from +8°C to +80°C. See Water Quality Standards and Recommendation on the next page.

For operation from -30°C to +8°C, a 50/50 mixture, by volume, of tap water and laboratory grade ethylene glycol is suggested.

Above +80°C and below -30°C, the user is responsible for fluids used.



**Never use pure ethylene glycol as a bath fluid. Above 80°C the user is responsible for the fluid used.**

## Filling Requirements

The bath work area has a high and low level marker to guide filling. The markers are 1 inch horizontal slits located in the center of the stainless steel baffle separating the work area and the pump assembly. The correct fluid level falls between these two markers. The heating and cooling coils will be exposed and may become damaged if the correct fluid level is not provided.

When pumping to an external system, keep extra fluid on hand to maintain the proper level in both the circulating lines and the external system.



**Never run the unit when the work area is empty.**

## Water Quality Standards and Recommendations

	Permissible (PPM)	Desirable (PPM)
<b>Microbiologicals</b> (algae, bacteria, fungi)	0	0
<b>Inorganic Chemicals</b>		
Calcium	<40	0.6
Chloride	250	<25
Copper	1.3	1.0
Iron	0.3	<0.1
Lead	0.015	0
Magnesium	<12	0.1
Manganese	0.05	<0.03
Nitrates\Nitrites	10 as N	0
Potassium	<20	0.3
Silicate	25	<1.0
Sodium	<20	0.3
Sulfate	250	<50
Hardness	17	<0.05
Total Dissolved Solids	50	10
<b>Other Parameters</b>		
pH	6.5-8.5	7-8
Resistivity	0.01*	0.05-0.1*

\* Megohm-Cm (Compensated at 25°C)

Unfavorably high total ionized solids (TIS) can accelerate the rate of galvanic corrosion. These contaminants can function as electrolytes which increase the potential for galvanic cell corrosion and lead to localized corrosion such as pitting which can be observed at the studs and on the outside surface of cooling coils. Eventually, the pitting will become so extensive that the coil will leak refrigerant into the water reservoir.

For example, raw water in the U.S. averages 171 ppm (as NaCl). The recommended level for use in a water system is between 0.5 to 5.0 ppm (as NaCl).

Recommendation: Initially fill the tank with distilled/deionized water. Do not use untreated tap water as the total ionized solids level may be too high.

Maintain this water quality at a resistivity of between 1 to 10 megohm-cm (compensated at 25°C) by using a purification system. Although the initial fill may be as high as 10 megohm-cm (compensated at 25°C), the desired level for long time usage is 1 to 3 megohm-cm (compensated at 25°C).

The above two recommendations will reduce the electrolytic potential of the water and prevent or reduce the galvanic corrosion observed.

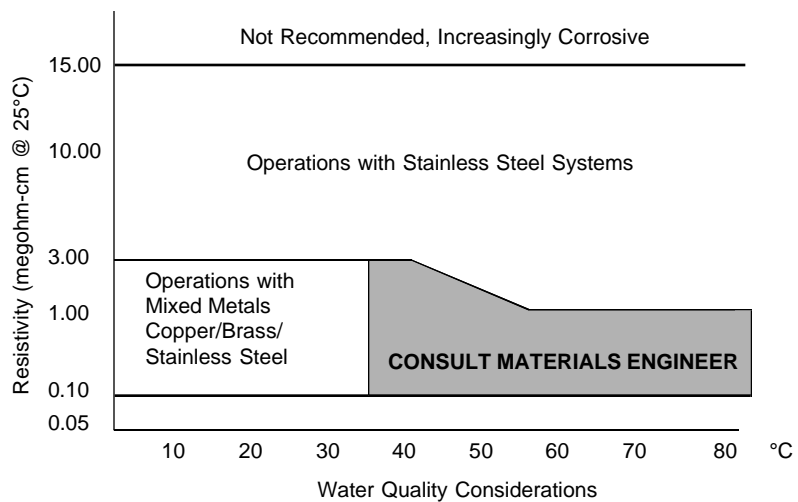

## Section IV Temperature Controller

### Start Up

Before starting the unit, check all electrical and plumbing connections and make sure the work area has been properly filled with bath fluid.

To start the bath press the I/O circuit breaker on the side of the control box to the I (power on) position. The pump will start and the controller will display the temperature of the fluid in the reservoir

The controller's COOL and HEAT indicators show the status of the refrigeration system and heater. The COOL indicator is lit when the refrigeration system is removing heat from the cooling fluid. The HEAT indicator is lit when the heater is on. The HEAT indicator flashes when the heater is pulsating. A balance between COOL and HEAT controls the temperature.

**NOTE:** Below 50°C the refrigeration system is on unless the setpoint is more than 2°C above the bath temperature. This allows for rapid heat up. Above 50°C the refrigeration system is off unless the setpoint is more than 2°C below the bath temperature. This allows for rapid cool down.

### Controller Keypad & Display

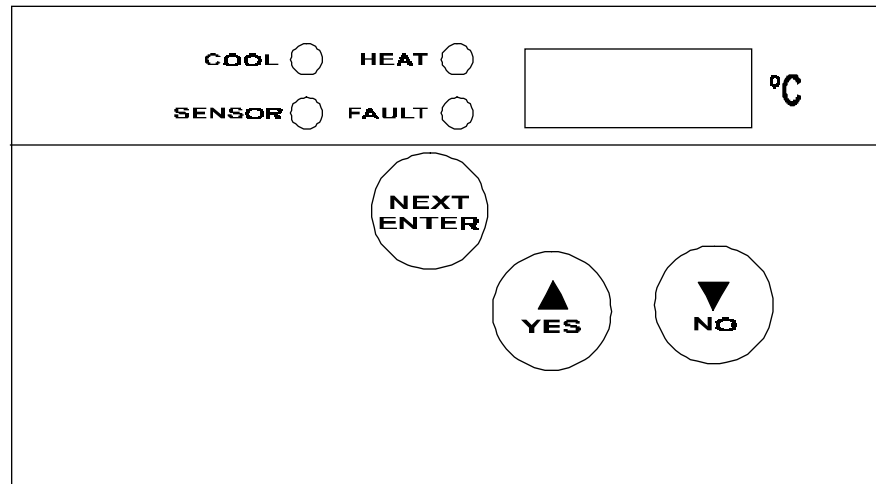

The digital controller controls temperature using a PID (Proportional-Integral-Derivative) algorithm. It is designed with self-diagnostic features and easy to use operator interface.

#### **NEXT ENTER**

Use this key to scroll forward through the menus and also to accept and save changes.

#### **YES, ▲**

This dual purpose key is used to answer Yes to Y/N questions or to increment numerical values upward for setting numeric values.

## **NO, ▼**

This dual purpose key is used to answer No to Y/N questions or to decrement numerical values downward for setting numeric values.

## **Changing a Value**

The **YES** key increments the value. The **NO** key decrements the value.

The display will flash as soon as either key is depressed, and will continue to flash until the **NEXT ENTER** key is pressed twice to accept the new value.

The new value will not be used by the controller until the **NEXT ENTER** key is depressed twice and the display stops flashing.

**NOTE:** If the **ENTER** key is not depressed twice within 10 seconds, the controller will time out and the new value will not be accepted. The controller will revert to the previous setpoint value.

The controller will not allow you to enter a value above the maximum (+150°C) or below the minimum (-25°C).

## **Controller Displays**

An alphanumeric display presents numeric readings of various operating conditions within the bath. Display function is selected by pressing the appropriate keys to move through a menu of available information.

The controller has several loops. The Operator's Loop displays the bath temperature and is used to change the setpoint, see page 12. The Setup Loop is used to adjust the controller's PID parameters, select the internal or remote sensor, and set the high/low temperature limits. It is also used to select RS232 operation. See page 13-14. The Setup Loop can be accessed from the Operator's Loop by pressing and holding the key combinations shown on Figure 1 on the next page.

When the controller is first powered up it enters the Operator's Loop. The display will indicate the bath temperature.

**NOTE:** If altering any settings in the various loops, should you desire to return to the temperature display and abort any changes, keep pressing the **NEXT ENTER** until the display reads **Stor**, then press **NO**.

## Operator's Loop

When the controller is first powered up it enters the Operator's Loop, displaying reservoir fluid temperature. Press the NEXT ENTER key to view the setpoint.

SP displays the controller setpoint. The display will flash between SP and the actual setpoint number. Use the YES/NO keys to change the setpoint value. Once the desired setpoint is displayed, press the NEXT ENTER key twice.

**NOTE:** If the bath is controlled via RS232 communications, the setpoint can not be changed from the keypad.

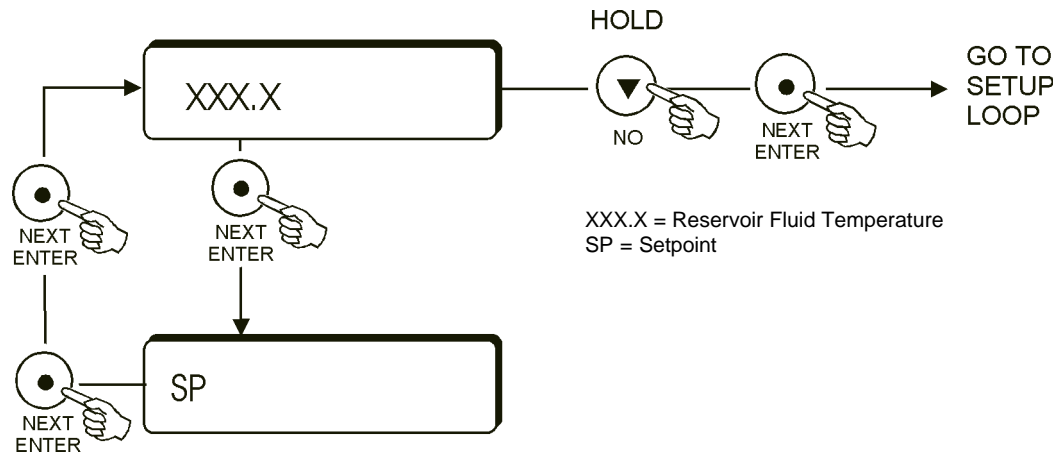

Figure 1 Operator's Loop

## Setup Loop

The Setup Loop is used to adjust the controller's PID parameters, select the internal (1) or remote (2) sensor, and set the high/low temperature limits, and to select RS232 operation.

Enter the Setup Loop from the Operator's Loop by pressing and holding the NO key, then press the NEXT ENTER key. Use the YES/NO keys to adjust the values. Press the NEXT ENTER key twice to accept the new value.

While in the Setup Loop, if any key is not pressed during a one minute time span, the controller will automatically return to the Operator's Loop temperature display.

**NOTE:** If the unit exceeds either temperature limit, the appropriate error message will flash, see page 15. The unit will not shut down (unless the temperature exceeds the high temperature cutout setting, see page 17).

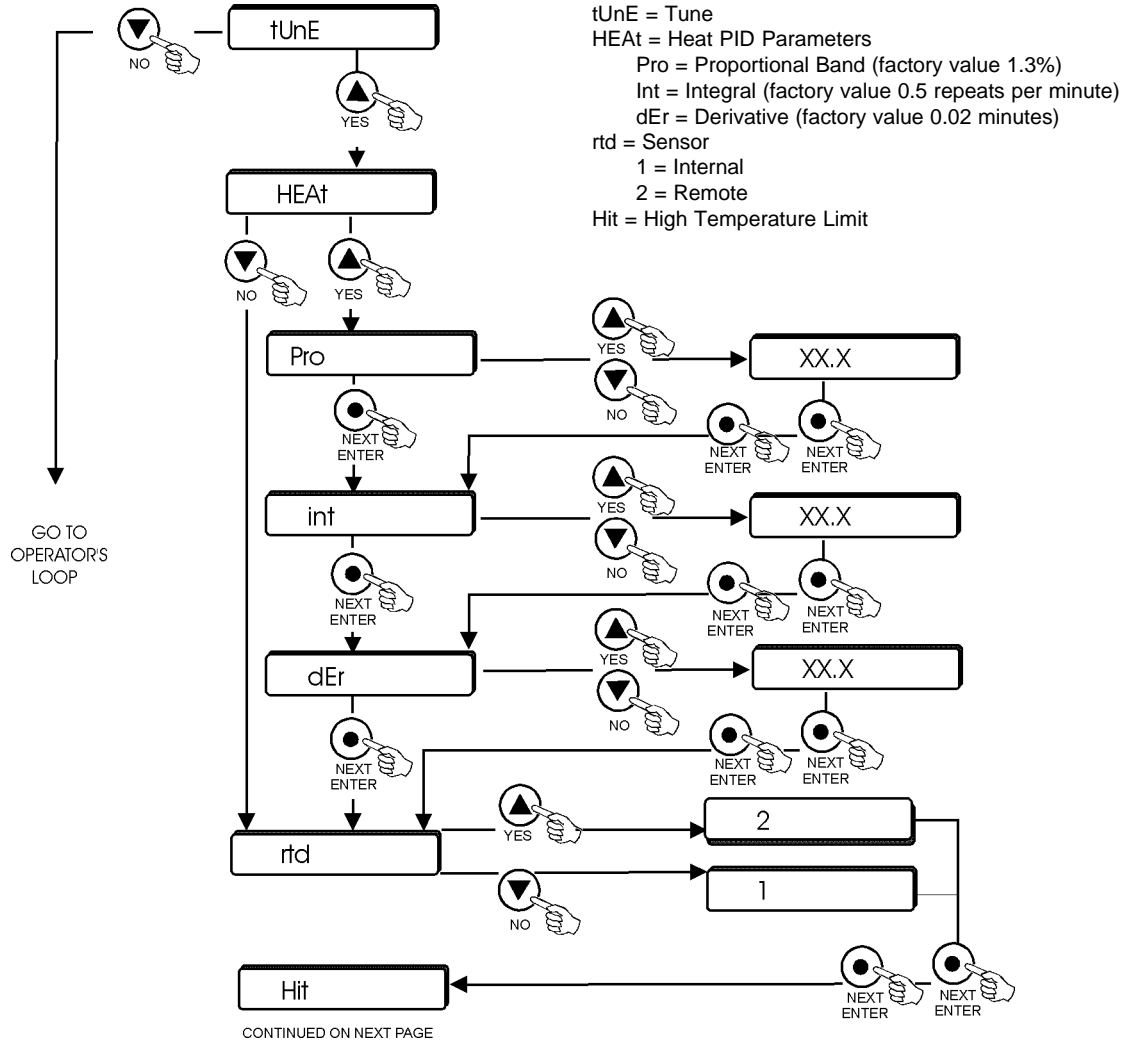

Figure 2 Setup Loop (1 of 2)

CONTINUED FROM PREVIOUS PAGE

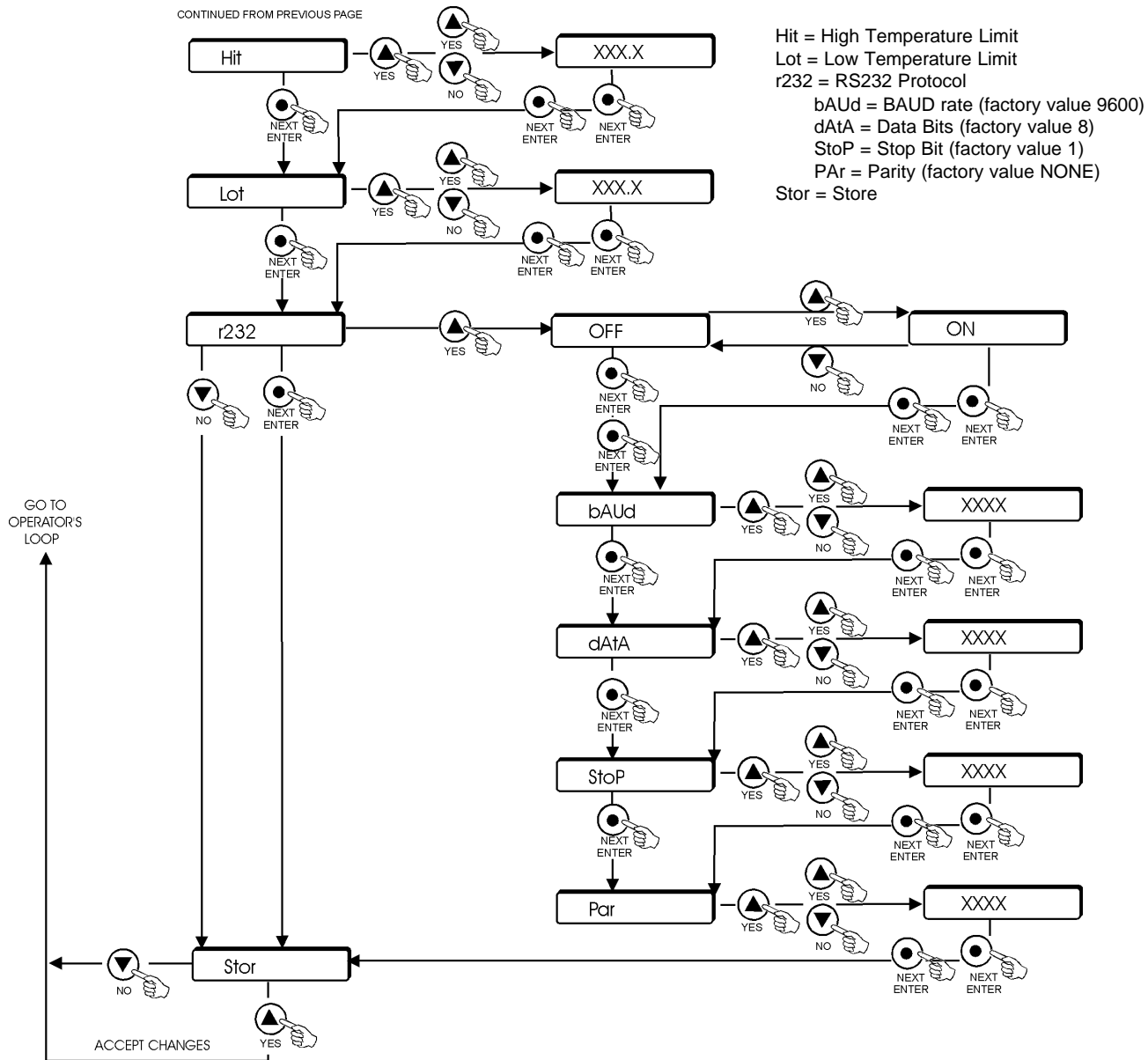

Figure 2 Setup Loop (2 of 2)

## Error Messages

Error	Action
<b>Er00:</b>	ROM Checksum
Er01:	RAM Test Failed
Er03	Keypad Test Failed
Er04-13:	Interrupt Error
Er14:	Synchronous Error
Er15:	Asynchronous Error
Er16:	Bad Calibration
Er19:	Low Temp Limit
Er21:	High Temp Limit
Er23:	RTD2 Shorted
Er24:	RTD2 Open/Not Installed
Er25:	RTD1 Shorted
Er26:	RTD1 Open
Er34:	High Temperature Cutout

**NOTE:** Errors 1 through 16 will lockup the controller keypad.

## Autorefill (Optional)

An optional autorefill device is designed to maintain the correct level of cooling fluid in the reservoir. The device consists of a float switch and a solenoid valve. If the cooling fluid level falls, the float switch will open the solenoid valve and allow make-up fluid to fill the reservoir. Once the cooling level reaches the proper level, the float switch will rise and the solenoid valve will close.

The plumbing connection for the autorefill device, labeled WATER INLET, is located on the rear of the autorefill assembly. The connection is 3/8 inch OD stainless steel. Remove the nut and install the tubing from your make-up fluid source. Reinstall the nut and tubing on to the connection.

Tubing is available from NESLAB. Contact our Sales Department for more information (see Preface, After-sale Support).

The autorefill device requires its own source of electrical power. The connector for the line cord (provided with the assembly) is also located on the rear of the autorefill device. The connector is labelled POWER.

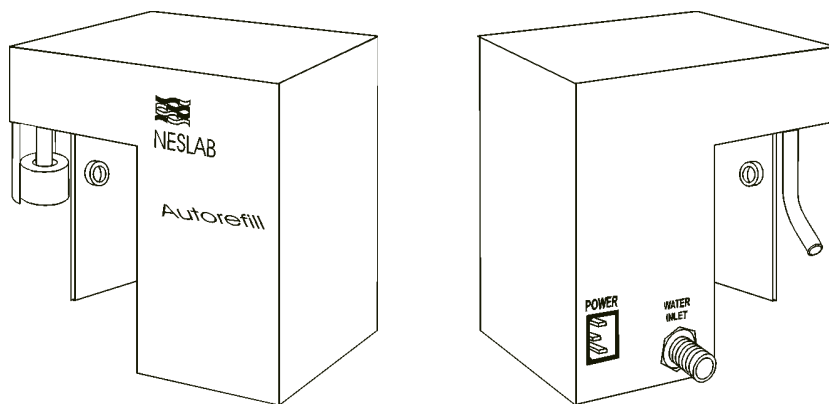

Autorefill Device

## High Temperature/ Low Liquid Level Safety

To protect your application, the adjustable High Temperature/Low Liquid Level Safety (HIGH TEMP/LOW LEVEL) ensures the heater will not exceed temperatures which can cause serious damage to your unit. A single temperature sensor, located on the heater coils in the bath, monitors both conditions. A High Temperature/Low Liquid Level fault occurs when the temperature of the sensor exceeds the set temperature limit.

In the event of a fault, the unit will shut down. The cause of the fault must be identified and corrected before the unit can be restarted.

The safety is not preset and must be adjusted during initial installation.

To set the safety, locate the HIGH TEMP/LOW LEVEL SAFETY adjustment dial on the right side of the pump box. Turn the dial fully clockwise and press the red RESET switch located next to the adjustment dial. **NOTE:** On units without a reset switch turn the I/O switch off then back on.

Start the unit. Adjust the setpoint for a few degrees higher than the highest desired fluid temperature and allow the bath to stabilize at the temperature setpoint. Turn the HIGH TEMP/LOW LEVEL SAFETY dial counter-clockwise until you hear a click and the unit shuts down. The yellow FAULT LED on the temperature controller will light to indicate a fault has occurred.

Cool the bath and then, without moving the adjustment dial, press the red RESET switch or turn the I/O switch off then back on.

**NOTE:** The safety switch has a temperature range of 50°C to 180°C. The minimum high temperature safety setting is 50°C.

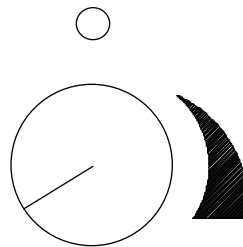

High Temperature/Low Liquid Level Safety  
(Some units do not have a reset switch.)

## 9-Pin Accessory Connector

The unit is equipped with two female 9-pin D-connectors located on the rear of the control box. One is used for RS232 communication, the other is used with an optional remote sensor.



### RS232 Pin Connections

Pin #	Function
1	No connection.
2	TX = Transmitted data
3	RX = Received data
4	No connection
5	GND = Signal ground
6	No connection.
7	CTS = Clear to send
8	RTS = Request to send
9	No connection

Hardware	Internal Connector	Mating Connector
	AMP Part# 745491-2	AMP Part# 745492-2

### Remote Sensor Connections

Pin #	Function
1	3-wire RTD connection A
2	No connection
3	No connection
4	3-wire RTD connection B
5	No connection
6	No connection.
7	No connection
8	No connection
9	3-wire RTD connection C

Hardware	Internal Connector	Mating Connector
	AMP Part# 745491-2	AMP Part# 745492-2

## Section V Maintenance



**To avoid electrical shock, disconnect the mains cord prior to removing any access panels or covers.**

### Service Contracts

NESLAB offers on-site Service Contracts that are designed to provide extended life and minimal down-time for your unit. For more information, contact our Service Department (see Preface, After-sale Support).

### Condenser

For proper operation, the unit needs to pull substantial amounts of air through a condenser. A build up of dust or debris on the fins of the condenser will lead to a loss of cooling capacity.

Periodic vacuuming of the condenser is necessary. To access the condenser the front grille must be removed.



**The unit must be turned off before the front panel is removed.**

RTE-111 units have a one-piece grille assembly. Pull forward to remove.

RTE-211 and RTE-221 units have a two piece grille assembly. First remove the left (blue-colored) section by simply pulling it forward. Pull forward on the remaining (white-colored) section to remove it.

The frequency of cleaning depends on the operating environment. After initial installation, we recommend a monthly visual inspection of the condenser. After several months, the frequency of cleaning will be established.

## Reservoir Cleaning

Routine cleaning can be achieved by simply sponging down the seamless stainless steel tank with tap water. (Dish washing detergent may be used but the tank must be thoroughly rinsed.)

To gain access to the entire reservoir the pump box and reservoir cover should be removed.

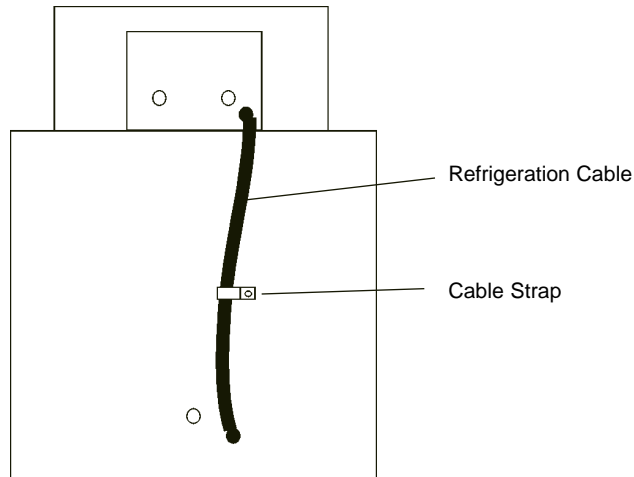

Remove the line cord from the rear of the unit and then remove the four screws (two on each side) securing the reservoir's cover.

To get slack on the refrigeration cable, remove the cable strap. The cable itself does not need to be disconnected.

Turn the cover assembly over and carefully place it on a supporting platform.

## Algae

To restrict the growth of algae in the bath, we recommend the bath cover be kept in place and that all circulation lines be opaque. This will eliminate the entrance of light required for the growth of most common algae.

NESLAB recommends the use of Chloramine-T, 1 gram per 3½ liters.

# Additional Loops

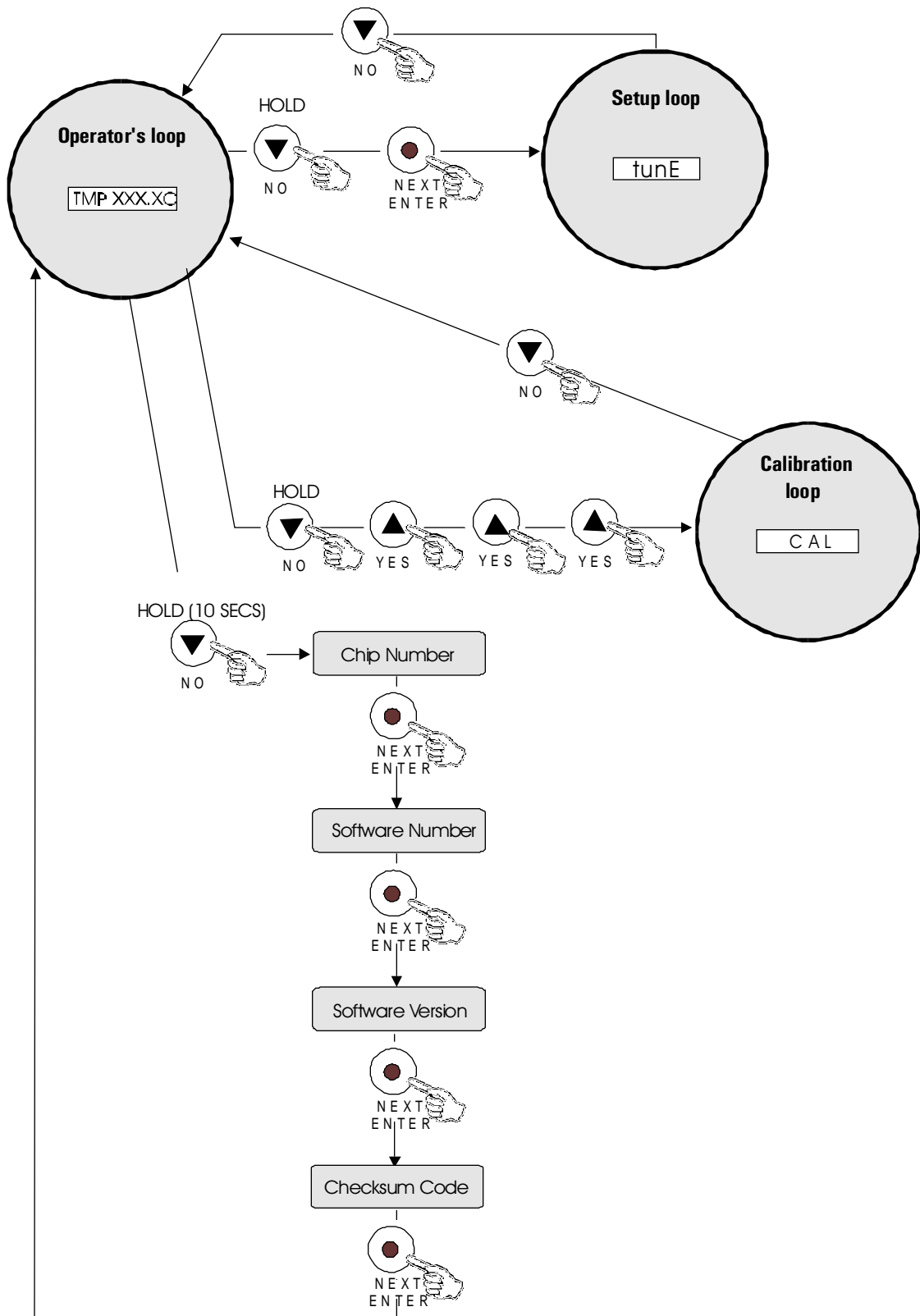

Figure 3 Changing Loops

## Calibration Loop

The Calibration Loop is used to calibrate the RTD high and low temperature. The controller's internal temperature sensor is factory calibrated. We recommend calibrating any remote sensor.

Enter the Calibration Loop from the Operator's Loop by pressing and holding the NO key while pressing the YES key three times.

**NOTE:** Depressing the NEXT ENTER key when the controller displays rtd1 will change the display to rtd2. The menus for rtd2 are identical to the rtd1 menus.

## Calibration Procedure

Install a calibrated reference thermometer in the bath. (For remote mode, also install the sensor in the bath.) Place the cover on the unit.

The procedure involves using the Operator's, Setup and Calibration Loops. Go to the Setup Loop and place the unit in the internal or remote RTD mode of operation (RTD1 = Internal Probe, RTD2 = Remote Probe). Return to the Operator's Loop adjust the setpoint to an appropriate high-end temperature.

Once the bath reaches the setpoint and stabilizes, go to the Calibration Loop and, as illustrated on the next page, enter the actual reference thermometer reading at the r1H or r2H prompt.

Save the change and return to the Operator's Loop. Adjust the setpoint to an appropriate low-end temperature. Once the bath reaches the setpoint and stabilizes, return to the Calibration Loop and enter the reference thermometer reading at the r1L or r2L prompt. Save the change.



**Do not pick points that are outside the safe operating limits of the fluid in your application. For example with a water bath, 90°C and 5°C would be typical calibration points.**



## Section VI Troubleshooting

### Checklist

#### Unit will not start

Make sure the voltage of the power source meets the specified voltage,  $\pm 10\%$ . Refer to the serial number label on the rear of the unit to identify the specific electrical requirements of your unit.

Check the High Temperature/Low Liquid Level Safety. If the FAULT light is on, make sure the fluid level in the bath is between the marks in the baffle and the HIGH TEMP/LOW LEVEL SAFETY setting is greater than the fluid temperature. Push the RESET switch, or, for units without reset switches, turn the I/O switch off then back on, and attempt to restart.

#### Loss of cooling capacity

Be sure the cooling capacity of the unit has not been exceeded if circulating to an external system.

When the unit is shut off, wait approximately five minutes before restarting. This allows time for the refrigeration pressures to equalize. If the pressures are not allowed to equalize, the compressor will short-cycle (clicking sound) and no cooling will occur.

Proper ventilation is required for heat removal. Make sure ventilation through the front and rear panels is not impeded and the panels are free of dust and debris.

Ice build up on the cooling coils can act as insulation and lower the cooling capacity. Raise the temperature of the bath to de-ice the cooling coil and increase the concentration of non-freezing fluid.

#### No external circulation

Check for obstructions, kinks, or leaks in the circulation tubing.

Circulation will cease when the pump head has been exceeded.

#### No/poor temperature control

Check RS232/remote operation on or off.

Check remote sensor connection. Perform calibration.

### Service Assistance and Technical Support

If, after following these troubleshooting steps, your unit fails to operate properly, contact our Customer Service Department for assistance (see Preface, After-sale Support). In addition to arranging warranty service, our Service Department can provide you with a wiring diagram and a complete list of spare parts for your unit. Before calling, please obtain the following:

*Part number*

*Serial number*

## Section VII Programming Software

### NEScom Software/ RS232 Communication

The NESLAB Communications Software is a user friendly software that allows you to automate your temperature control process. The software includes a 3½" disk, Comprehensive Operator's Manual and a toll-free number to a trained technical staff.

NEScom Software allows you to write custom temperature programs for our Digital or Microprocessor based temperature control apparatus. Choose upper or lower temperature limits and monitor system status with an alarm. NEScom can also record your results on a user selectable graph. NesCom must be used with an IBM or 100% compatible computer.

Select from easy to use product icons.

Create graphs and charts.

Easily configure ramping functions which set the setpoint over time.

View pop-up alarm windows which display if an alarm condition occurred.

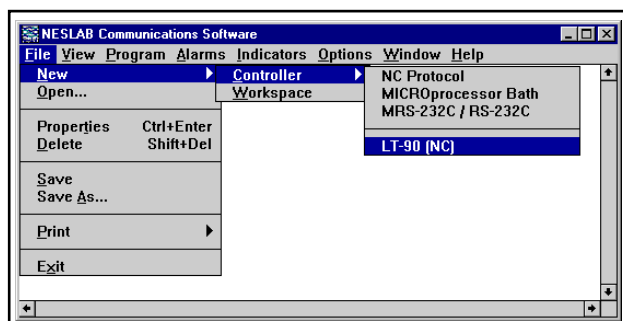

Select software functions from the easy to use pulldown menus.



View a virtual controller screen which allows remote monitoring and operation of product control panel.

### **MANTENIMIENTO PERIODICO**

Inspeccione periódicamente el fluido del reservorio. Si es necesaria una limpieza, rocíe el reservorio con un fluido de limpieza compatible con el sistema de circulación y el fluido refrigerante.

Antes de cambiar el fluido refrigerante, suba la temperatura de operación de la unidad para descongelar los serpentines de refrigeración.

Es necesario un vaciado periódico de las aletas del condensador. La frecuencia de limpieza depende del entorno en que funciona el aparato. Recomendamos una inspección visual mensual del condensador después de la instalación inicial. Después de varios meses, quedará establecida la frecuencia de limpieza.