

GP Series
Constant Temperature
Bath and Circulator

NESLAB Manual P/N 000800
Rev . 07/16/97

Instruction and Operation Manual

GP-Series Constant Temperature Bath and Circulator Instruction and Operation Manual

Table of Contents

PREFACE	
	Compliance 2
	Unpacking 2
	Warranty 2
	After-sale Support 2
SECTION I	
Safety	
	Warnings 3
SECTION II	
General Information	
	Description 4
	Specifications 4
SECTION III	
Installation	
	Site 6
	Electrical Requirements 6
	Plumbing Requirements 6
	Fluids 7
	Filling Requirements 7
SECTION IV	
Controllers	
	Controllers 8
	Analog 8
	Digital 9
	High Temperature/Low Liquid Level Safety 10
	Tap Water Cooling Coil 11
	Thermometer 11
SECTION V	
Maintenance	
	Service Contracts 12
	Cleaning 12
	Algae 12
SECTION VI	
Troubleshooting	
	Checklist 13
	Service Assistance 13
	Technical Support 13
SECTION VII	
Warranty 14

Preface

Compliance

Products tested and found to be in compliance with the requirements defined in the EMC standards defined by 89/336/EEC as well as Low Voltage Directive (LVD) 73/23/EEC can be identified by the CE label on the rear of the unit. The testing has demonstrated compliance with the following directives:

LVD, 73/23/EEC	Complies with UL 3101-1:93
EMC, 89/336/EEC	EN 55011, Class A Verification EN 50082-1:1992 IEC 1000-4-2:1995 IEC 1000-4-3:1994 IEC 1000-4-4:1995

For any additional information refer to the Letter of Compliance that shipped with the unit (Declaration of Conformity).

Unpacking

Retain all cartons and packing material until the unit is operated and found to be in good condition.

If the unit shows external or internal damage, or does not operate properly, contact the transportation company and file a damage claim. Under ICC regulations, this is your responsibility.

Warranty

The unit has a warranty against defective parts and workmanship is for one full year from date of shipment. See back page for more details.

After-sale Support

NESLAB is committed to customer service both during and after the sale. If you have questions concerning the operation of your unit, contact our Sales Department. If your unit fails to operate properly, or if you have questions concerning spare parts or Service Contracts, contact our Customer Service Department. Before calling, please obtain the following information from the unit's serial number label:

- *BOM number* _____

- *Serial number* _____

Section I Safety

Warnings

Make sure you read and understand all instructions and safety precautions listed in this manual before installing or operating your unit. If you have any questions concerning the operation of your unit or the information in this manual, contact our Sales Department. Addresses and phone numbers for all our NESLAB Sales and Service Centers are printed on the back cover of this manual.

Performance of installation, operation, or maintenance procedures other than those described in this manual may result in a hazardous situation and may void the manufacturer's warranty.

Observe all warning labels.

Never remove warning labels.

Never operate damaged or leaking equipment.

Never use flammable or corrosive fluids with this unit.

Never operate the unit without bath fluid in the bath.

Always turn off the unit and disconnect the line cord from the power source before performing any service or maintenance procedures, or before moving the unit.

Always empty the bath before moving the unit.

Never operate equipment with damaged line cords.

Refer service and repairs to a qualified technician.

In addition to the warnings listed above, warnings are posted throughout the manual. These warnings are designated by an exclamation mark inside an equilateral triangle with text highlighted in bold print. Read and follow these important instructions. Failure to observe these instructions can result in permanent damage to the unit, significant property damage, or personal injury, or death.

Section II General Information

Description

The GP-Series Constant Temperature Baths are designed to provide temperature control for applications requiring a fluid work area or pumping to an external system.

The units consist of a heater, stirrer or optional circulation pump, stainless steel bath, and temperature controller.

Specifications

GP Series	
Temperature Range <i>Analog Controller</i> <i>Digital Controller</i>	ambient to +150°C ambient to +150°C
Temperature Stability¹	±0.03°C
Pump Capacity^{1,2}	

1. Specifications listed for units operating at +37°C bath temperature, +21°C (+70°F) ambient, with tap water as bath fluid.
2. The circulation pump is an optional feature. It is factory installed and must be specified at the time of order.

	GP-100	GP-200	GP-300
Heater Watts	1200		
Bath Work Area (L x W x D) Inches Centimeters	12.7 x 15.2 x 14.6 5 x 6 x 5 ¾	10 x 10 ³ / ₈ x 5 ¾ 25.4 x 26.4 x 14.6	10 x 10 ³ / ₈ x 8 ½ 25.4 x 26.4 x 21.6
Bath Volume Gallons Liters	1.3 5.0	3.2 12.0	5.25 20.0
Unit Dimensions (H x W x D) Inches Centimeters	13 ¼ x 8 ¾ x 13 33.7 x 22.2 x 33.0	13 ¼ x 12 ½ x 18 ½ 33.7 x 31.7 x 47.0	16 5/8 x 12 ½ x 18 ½ 41.9 x 31.7 x 47.0
Power Requirements Volts Hz Amps	115 60 12		
	220/240 50 7		
Shipping Weight Pounds Kilograms	33 15	49 23	54 25
	GP-400	GP-500	
Heater Watts	1200		
Bath Work Area (L x W x D) Inches Centimeters	20 x 10 ³ / ₈ x 5 ¾ 50.8 x 26.4 x 14.6	17 x 10 ³ / ₈ x 11 ½ 43.2 x 26.4 x 29.2	
Bath Volume Gallons Liters	5.5 21	11 42	
Unit Dimensions (H x W x D) Inches Centimeters	13 ¼ x 12 ½ x 28 ¼ 33.7 x 31.7 x 71.8	19 ½ x 12 ½ x 25 ½ 49.5 x 31.7 x 64.8	
Power Requirements Volts Hz Amps	115 60 12		
	220/240 50 7		
Shipping Weight Pounds Kilograms	65 30	130 60	

Section III Installation

Site

The unit should be located on a sturdy table or bench top. Ambient temperatures should be inside the range of +50°F to +90°F (+10°C to +32°C).



Never place the unit in a location where excessive heat, moisture, or corrosive materials are present.

A minimum clearance of 6 inches (15 centimeters) between the rear of the unit and the nearest wall is required for adequate ventilation through the pump box. This space will also accommodate the pump connections, the tap water cooling coil connections.

Excessively dusty areas should be avoided and a periodic cleaning schedule should be instituted (see Section VI, Cleaning).

Electrical Requirements

Refer to the serial number label on the rear of the unit to identify the specific electrical requirements of your unit.

Ensure the voltage of the power source meets the specified voltage, $\pm 10\%$.

The unit construction provides extra protection against the risk of electric shock by grounding appropriate metal parts. The extra protection may not function unless the power cord is connected to a properly grounded outlet. It is your responsibility to assure that a proper ground connection is provided.

Plumbing Requirements

Hose Connections (if equipped with circulation pump)

The pump connections are located at the rear of the pump box and are labelled. These connections are stainless steel serrated hose connections that accept $\frac{3}{8}$ inch ID flexible tubing.

Flexible tubing, if used, should be of heavy wall or reinforced construction. Make sure all tubing connections are securely clamped. Avoid running tubing near radiators, hot water pipes, etc. If substantial lengths of tubing are necessary, insulation may be required for improved temperature control.

Please consider hard plumbing circulation lines when excessively high fluid temperatures are required.

Tubing and insulation are available from NESLAB. Contact our Sales Department for more information (see Preface, After-sale Support).

Pumping (if equipped)

The pump is designed to deliver a flow of 9 liters/minute (2.3 gallons/minute) at 0 feet of head. To prevent unwanted flow, the bath is supplied with two stainless steel disks which block the PUMP INLET and PUMP OUTLET.

The disks must be removed when flow is required. To prevent leaking around the inlet and outlet connections, be sure the two Teflon® O-rings remain in place. To prevent distortion of the O-rings, only tighten the connections "hand tight." Once the hose connections are made, the pump must be properly plumbed to an external system. It is important the bath is not in operation when all plumbing work is done.

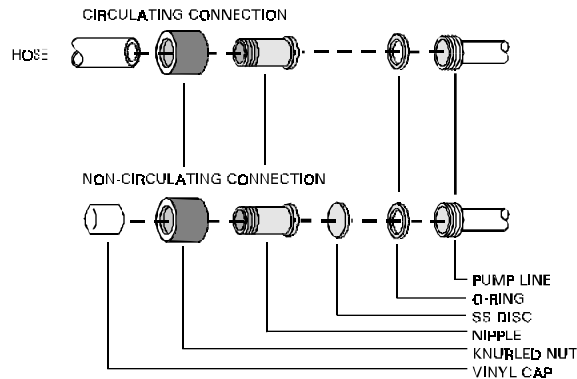

It is important to keep the distance between the unit and the external system as short as possible, and to use the largest diameter tubing practical. Tubing should be straight and without bends. If diameter reductions must be made, make them at the inlet and outlet of the external system, not at the unit.

If the bath is not used for external circulation, make sure the stainless steel disks are in place prior to operating the bath.

Fluids

Tap water is the recommended fluid for operation from ambient to +80°C.

Above +80°C, the user is responsible for fluids used.



Never use flammable or corrosive fluids with this unit.

Filling Requirements

The bath work area has a high and low level marker to guide filling. The markers are 1 inch horizontal slits located in the center of the stainless steel baffle that separates the work area and the pump assembly. The correct fluid level falls between these two markers. If the correct fluid level is not maintained, the heater will be exposed and may become damaged.

When pumping to an external system, keep extra fluid on hand to maintain the proper level as the circulating lines and external system are filled.



Never run the unit when the work area is empty.

Section IV Controllers

Controllers

Two temperature controllers are available with GP-Series baths: Analog and Digital. This section explain the installation and operation of the controllers.

Analog

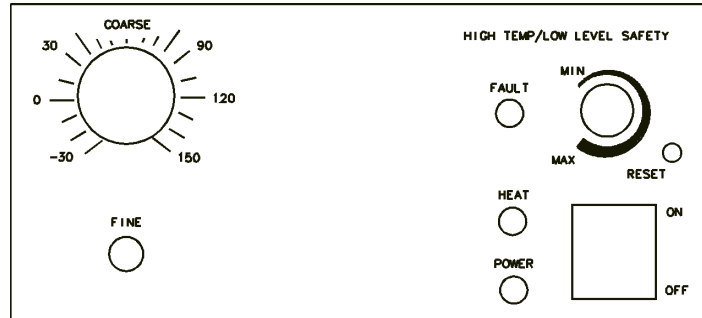

Analog Temperature Controller (Front View)

Start Up

Before starting the unit, double check all electrical and plumbing connections and make sure the work area has been properly filled with bath fluid.

To start the unit, press the ON/OFF button. The pump will start and the ON lamp will light.

Temperature Adjustment

To adjust the bath temperature, turn the calibrated COARSE dial and position the reference line as close to the temperature setpoint as possible. Use the FINE dial and the bath thermometer to make fine adjustments to the bath temperature.

The HEAT lamp indicates the status of the heater. As the temperature of the fluid in the bath approaches the temperature setpoint, the lamp will cycle on and off to indicate the approximate duty cycle of the heater.

Digital

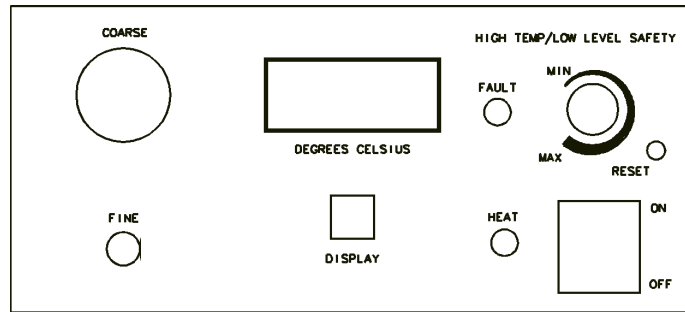

Start Up

Before starting the unit, double check all electrical and plumbing connections and make sure the work area has been properly filled with bath fluid.

To start the unit, press the ON/OFF switch. The pump will start and the display will indicate the temperature of the fluid in the bath.

Temperature Adjustment

To display the temperature setpoint, press the DISPLAY button. To adjust the setpoint, press the DISPLAY button and turn the COARSE and FINE dials until the temperature setpoint is indicated on the LED display.

NOTE: Inadvertent movement of the COARSE and/or FINE dials, regardless of the position of the DISPLAY button, will result in a change in the setpoint. This change will not be immediately reflected on the LED display, unless the DISPLAY button is pressed. The display will eventually change as the unit responds to the new setpoint.

The HEAT LAMP indicates the status of the heater. As the temperature of the fluid in the bath approaches the temperature setpoint, the LAMP will cycle on and off to indicate the approximate duty cycle of the heater.

High Temperature/ Low Liquid Level Safety

The unit is equipped with an adjustable High Temperature/Low Liquid Level Safety (HIGH TEMP/LOW LEVEL). The safety prevents the heater from reaching excessively high temperatures that can cause serious damage to the unit. A single temperature sensor, located on the heater coils in the bath, is used to monitor both conditions. A High Temperature/Low Liquid Level fault occurs when the temperature of the sensor exceeds the set temperature limit. In the event of a fault, the unit will shut down. The cause of the fault must be identified and corrected before the unit can be restarted.

The safety is not pre-set and must be adjusted during initial installation.

HIGH TEMP/LOW LEVEL SAFETY

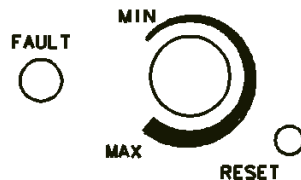

To set the safety, locate the adjustment dial on the front of the control box. It is labelled HIGH TEMP/LOW LEVEL SAFETY. Turn the dial fully clockwise and press the RESET button. **NOTE:** On units without a reset button turn the ON/OFF switch off and then back on.

Start the unit. Adjust the temperature setpoint for a few degrees higher than the highest desired operating temperature and allow the bath to stabilize at the setpoint. Turn the HIGH TEMP/LOW LEVEL SAFETY dial counter-clockwise until you hear a click and the unit shuts down. The red FAULT lamp on the front of the pump box will light to indicate a fault has occurred.

The safety is now set. Allow the fluid to cool below the cutout temperature and then, without moving the adjustment dial, press the RESET button or turn the ON/OFF switch off and then back on.

If a fault occurs, the RESET button must be pressed or the ON/OFF switch turned off and then back on before the unit will start.

NOTE: The minimum high temperature safety setting is 50°C.

Tap Water Cooling Coil

The unit is equipped with a cooling coil located in the bath. The work area can be cooled and temperature stability improved by circulating cold fluid through the coil. For best results, the fluid should be 5°C or more below the temperature setpoint. The required flow rate of the fluid depends on the type of fluid and the setpoint.

The plumbing connections for the cooling coil are 3/8 inch OD stainless steel tubes located at the rear of the pump box. These connections will accept 3/8 or 5/16 inch ID flexible tubing. A 3/8 inch ID is the minimum recommended tubing diameter. Tubing is available from NESLAB. Contact our Sales Department for more information (see Preface, After-sale Support).

Connect one COOLING COIL tube to the cold fluid source. Connect the other COOLING COIL tube to the cold fluid return (or drain, if tap water is being used).

Thermometer

Units with an Analog temperature controller will accept a glass tube thermometer. Insert the thermometer in the grommet located on the left side of the work area.

Section V Maintenance

Service Contracts

NESLAB offers on-site Service Contracts that are designed to provide extended life and minimal down-time for your unit. For more information, contact our Customer Service Department (see Preface, After-sale Support).

Cleaning

Periodically clean the case and stainless steel bath using a mild soapy solution. **Do not use steel wool; its abrasiveness will lead to rusting.** Dry the bath using a soft cloth.

Algae

To restrict the growth of algae in the bath, it is recommended that the bath cover be kept in place and that all circulation lines be opaque. This will minimize the entrance of light which is required for the growth of most common algae.

NESLAB recommends the use of Chloramine-T, one gram per gallon.

Section VI Troubleshooting

Checklist

Unit will not start

Ensure the voltage of the power source meets the specified voltage $\pm 10\%$. Refer to the serial number label on the rear of the unit to identify the specific electrical requirements of your unit.

Check the High Temperature/Low Liquid Level Safety. If the FAULT light is on, make sure the fluid level in the bath is between the marks in the baffle and the HIGH TEMP/LOW LEVEL SAFETY setting is greater than the bath temperature. Push the RESET button or, for units without a reset button, turn the ON/OFF switch off and then back on and attempt to restart.

No external circulation

Make sure the stainless steel disks on the PUMP INLET and PUMP OUTLET have been removed.

Check for obstructions, kinks, or leaks in the circulation tubing.

Circulation will cease when the pump head pressure has been exceeded.

Check the High Temperature/Low Liquid Level Safety. If the FAULT light is on, make sure the fluid level in the bath is between the marks in the baffle and the HIGH TEMP/LOW LEVEL SAFETY setting is greater than the bath temperature. Push the RESET button or, for units without a reset button, turn the ON/OFF switch off and then back on and attempt to restart.

Service Assistance

If, after following these troubleshooting steps, your units fails to operate properly, contact our Service Department for assistance (see Preface, After-sale Support). Before calling, please obtain the following information:

BOM number

Serial number

Voltage of unit

Voltage of power source

Technical Support

Our Customer Service Department can provide you with a wiring diagram and a complete list of spare parts for your unit. Before calling, please obtain the following information:

BOM number

Serial number

WARRANTY

NESLAB Instruments, Inc. warrants for 12 months from date of shipment any NESLAB unit according to the following terms.

Any part of the unit manufactured or supplied by NESLAB and found in the reasonable judgment of NESLAB to be defective in material or workmanship will be repaired at an authorized NESLAB Repair Depot without charge for parts or labor. The unit, including any defective part must be returned to an authorized NESLAB Repair Depot within the warranty period. The expense of returning the unit to the authorized NESLAB Repair Depot for warranty service will be paid for by the buyer. NESLAB's responsibility in respect to warranty claims is limited to performing the required repairs or replacements, and no claim of breach of warranty shall be cause for cancellation or rescission of the contract of sales of any unit. With respect to units that qualify for field service repairs, NESLAB's responsibility is limited to the component parts necessary for the repair and the labor that is required on site to perform the repair. Any travel labor or mileage charges are the financial responsibility of the buyer.

The buyer shall be responsible for any evaluation or warranty service call (including labor charges) if no defects are found with the NESLAB product.

This warranty does not cover any unit that has been subject to misuse, neglect, or accident. This warranty does not apply to any damage to the unit that is the result of improper installation or maintenance, or to any unit that has been operated or maintained in any way contrary to the operating or maintenance instructions specified in NESLAB's Instruction and Operation Manual. This warranty does not cover any unit that has been altered or modified so as to change its intended use.

In addition, this warranty does not extend to repairs made by the use of parts, accessories, or fluids which are either incompatible with the unit or adversely affect its operation, performance, or durability.

NESLAB reserves the right to change or improve the design of any unit without assuming any obligation to modify any unit previously manufactured.

THE FOREGOING EXPRESS WARRANTY IS IN LIEU OF ALL OTHER WARRANTIES, EXPRESSED OR IMPLIED, INCLUDING BUT NOT LIMITED TO WARRANTIES OR MERCHANTABILITY AND FITNESS FOR A PARTICULAR PURPOSE.

NESLAB'S OBLIGATION UNDER THIS WARRANTY IS STRICTLY AND EXCLUSIVELY LIMITED TO THE REPAIR OR REPLACEMENT OF DEFECTIVE COMPONENT PARTS AND NESLAB DOES NOT ASSUME OR AUTHORIZE ANYONE TO ASSUME FOR IT ANY OTHER OBLIGATION.

NESLAB ASSUMES NO RESPONSIBILITY FOR INCIDENTAL, CONSEQUENTIAL, OR OTHER DAMAGES INCLUDING, BUT NOT LIMITED TO LOSS OR DAMAGE TO PROPERTY, LOSS OF PROFITS OR REVENUE, LOSS OF THE UNIT, LOSS OF TIME, OR INCONVENIENCE.

This warranty applies to units sold in the United States. Any units sold elsewhere are warranted by the affiliated marketing company of NESLAB Instruments, Inc. This warranty and all matters arising pursuant to it shall be governed by the law of the State of New Hampshire, United States. All legal actions brought in relation hereto shall be filed in the appropriate state or federal courts in New Hampshire, unless waived by NESLAB.