

**EX Series Bath Circulator  
with  
Microprocessor Controller**

Thermo NESLAB P/N 000261  
Rev. 10/26/00

**Instruction and Operation Manual**



# EX-Series Refrigerated Bath Circulator

## Table of Contents

<b>PREFACE</b>	Compliance ..... 2 Unpacking ..... 2 Warranty ..... 2 NES-care Extended Warranty ..... 2 After-sale Support ..... 2
<b>SECTION I Safety</b>	Warnings ..... 3
<b>SECTION II General Information</b>	Description ..... 4 Specifications ..... 4
<b>SECTION III Installation</b>	Site ..... 6 Electrical Requirements ..... 6 Plumbing Requirements ..... 7 Tap Water Cooling Coil ..... 9 Drain ..... 9 Fluids ..... 9 Filling Requirements ..... 9
<b>SECTION IV Controllers</b>	Microprocessor Controller ..... 10 Start Up ..... 12 Temperature Adjustment ..... 12 Alarm/External Functions ..... 13 Program Functions ..... 14 Program Control ..... 16 Error Messages ..... 19 Miscellaneous ..... 19 PID Control ..... 20 Restoring Factory PID Values ..... 20 Calibration ..... 21 High Temperature/Low Liquid Level Safety ..... 23
<b>SECTION V Maintenance</b>	Service Contracts ..... 24 Reservoir Cleaning ..... 24 Algae ..... 24
<b>SECTION VI Troubleshooting</b>	Checklist ..... 25 Service Assistance and Technical Support ..... 26
<b>APPENDIX A</b>	<b>RS-232</b>
<b>APPENDIX B</b>	<b>Programming Software</b>
<b>WARRANTY</b>	

## Preface

### Compliance

Products tested and found to be in compliance with the requirements defined in the EMC standards defined by 89/336/EEC as well as Low Voltage Directive (LVD) 73/23/EEC can be identified by the CE label on the rear of the unit. The testing has demonstrated compliance with the following directives:

LVD, 73/23/EEC	Complies with UL 3101-1:93
EMC, 89/336/EEC	EN 55011, Class A Verification
	EN 50082-1:1992
	IEC 1000-4-2:1995
	IEC 1000-4-3:1994
	IEC 1000-4-4:1995

For any additional information refer to the Letter of Compliance that shipped with the unit (Declaration of Conformity).

### Unpacking

Retain all cartons and packing material until the unit is operated and found to be in good condition. The unit control box for microprocessor units is packed in a separate carton. Be sure to locate this separate carton; do not dispose of it by mistake.

If the unit shows external or internal damage, or does not operate properly, contact the transportation company and file a damage claim. Under ICC regulations, this is your responsibility.

### Warranty

Units have a warranty against defective parts and workmanship for one full year from date of shipment. See back page for more details.

### ***NES-care* Extended Warranty Contract**

- Extend parts and labor coverage for an additional year.
- Worry-free operation.
- Control service costs.
- Eliminate the need to generate repair orders.
- No unexpected repair costs.

Other contract options are available. Please contact Thermo NESLAB for more information.

### After-sale Support

Thermo NESLAB is committed to customer service both during and after the sale. If you have questions concerning the operation of your unit or the information in this manual, contact our Sales Department. If your unit fails to operate properly or if you have questions concerning spare parts or Service Contracts, contact our Service Department.

Before calling, please refer to the serial number label on the rear of the case top to obtain the following information (see Section II, Description for the serial number label location):

- *BOM number* \_\_\_\_\_

- *Serial number* \_\_\_\_\_

## Section I Safety

### Warnings

Make sure you read and understand all instructions and safety precautions listed in this manual before installing or operating your unit. If you have any questions concerning the operation of your unit or the information in this manual, contact our Sales Department.

**Performance of installation, operation, or maintenance procedures other than those described in this manual may result in a hazardous situation and may void the manufacturer's warranty.**

**Transport the unit with care. Sudden jolts or drops can damage the refrigeration lines.**

**Observe all warning labels.**

**Never remove warning labels.**

**Never operate damaged or leaking equipment.**

**Never operate the unit without bath fluid in the bath.**

**Never use pure ethylene glycol as a bath fluid. A minimum 80/20 mixture of Ethylene Glycol and tap water is allowed.**

**For 220 - 240 volt units supplied without a line cord, use a harmonized (HAR) grounded 3-conductor cord, type H 05 V V - F , with conductors listed below. A suitable cord end is required for connecting to the equipment (see unit socket) and must terminate with an IEC approved plug for proper connection to power supply.**

<b>NON-BOOST HEATER UNITS</b>	<b>Nominal 1.0 mm<sup>2</sup> cross section rated 10 Amps Unit Socket: IEC - 320 C13</b>
-------------------------------	--

<b>BOOST HEATER UNITS</b>	<b>Nominal 1.5 mm<sup>2</sup> cross section rated 16 Amps Unit Socket: IEC - 320 C19</b>
---------------------------	--

**Always turn off the unit and disconnect the line cord from the power source before performing any service or maintenance procedures, or before moving the unit.**

**Always empty the bath before moving the unit.**

**Never operate equipment with damaged line cords.**

**Refer service and repairs to a qualified technician.**

In addition to the safety warnings listed above, warnings are posted throughout the manual. These warnings are designated by an exclamation mark inside an equilateral triangle with text highlighted in bold print. Read and follow these important instructions. Failure to observe these instructions can result in permanent damage to the unit, significant property damage, personal injury or death.

## Section II General Information

### Description

The EX Series Bath Circulators are designed to provide temperature control for applications requiring a fluid work area or pumping to an external system.

The units consist of a circulation pump, stainless steel bath, a work area cover, and a microprocessor temperature controller.

### Specifications

	EX-111	EX-211
<b>Temperature Range<sup>1</sup></b>	Ambient to +150°C	
<b>Temperature Stability<sup>2</sup></b>	±0.01°C	
<b>Pumping Capacity</b>	15 lpm at 0' (0 M) 0 lpm at 16' (4.9 M)	
<b>Heater</b> <i>Watts</i> <i>50 Hz Models</i>	800 1000	
<b>Bath Work Area</b> <i>(H x W x D)</i> <i>Inches</i> <i>Centimeters</i>	4 3/4 x 8 x 6 12.1 x 20.3 x 15.2	9 1/4 x 10 x 6 23.5 x 25.4 x 15.2
<b>Bath Volume</b> <i>Gallons</i> <i>Liters</i>	1.9 7.0	3.2 12.3
<b>Case Dimensions</b> <i>(L x W x D)</i> <i>Inches</i> <i>Centimeters</i>	17 x 10 5/16 x 15 7/8 43.2 x 26.2 x 40.3	17 x 12 3/8 x 18 3/8 43.2 x 31.4 x 46.7
<b>Power Requirements<sup>3</sup></b>	115 V, 60 Hz, 9 Amps 220/240 V, 50 Hz, 5.5 Amps	

1. Low-end temperature with tap water cooling. The controller may be set to -30°C, however to achieve temperatures below the specified range requires accessory cooling. Contact Thermo Neslab for more details.
2. Stability is a function of the bath fluid temperature. The use of a work area cover and tap water cooling may optimize bath stability for your work.
3. Power Board Transformer Fuse— T 2.0A 250V (Qty 1) [T=Time Delay].

## Specifications

	<b>EX-221</b>	<b>EX-411</b>	<b>EX-511</b>
<b>Temperature Range<sup>1</sup></b>	Ambient to +150°C		
<b>Temperature Stability<sup>2</sup></b>	±0.01°C		
<b>Pumping Capacity</b>	15 lpm at 0' (0 M) 0 lpm at 16' (4.9 M)		
<b>Heater</b> <i>Watts</i> <i>50 Hz Models</i>	800/800 boost 1000/800 boost	800 1000	800/800 boost 1000/800 boost
<b>Bath Work Area</b> <i>(H x W x D)</i> <i>Inches</i> <i>Centimeters</i>	9 1/4 x 10 x 9 23.5 x 25.4 x 22.9	19 1/4 x 10 x 6 48.9 x 25.4 x 15.2	16 1/4 x 10 x 12 41.3 x 25.4 x 30.5
<b>Bath Volume</b> <i>Gallons</i> <i>Liters</i>	5.4 20.5	5.8 22.0	11.0 41.5
<b>Case Dimensions</b> <i>(L x W x D)</i> <i>Inches</i> <i>Centimeters</i>	20 x 12 3/8 x 18 3/8 50.8 x 31.4 x 46.7	17 x 12 3/8 x 28 3/8 43.2 x 31.4 x 72.1	23 x 12 3/8 x 25 3/8 58.4 x 31.4 x 64.5
<b>Power Requirements</b>	115 V, 60 Hz, 16 Amps 220/240 V, 50 Hz, 10 Amps	115 V, 60 Hz, 9 Amps 220/240 V, 50 Hz, 5.5 Amps	115 V, 60 Hz, 16 Amps 220/240 V, 50 Hz, 10 Amps

1. Low-end temperature with tap water cooling. The controller may be set to -30°C, however to achieve temperatures below the specified range requires accessory cooling. Contact Thermo Neslab for more details.
2. Stability is a function of the bath fluid temperature. The use of a work area cover and tap water cooling may optimize bath stability for your work.
3. Power Board Transformer Fuse- T 2.0A 250V (Qty 1) [T=Time Delay].

## Section III Installation

### Site



**Never place the unit in a location where excessive heat, moisture, or corrosive materials are present.**

Lift the unit by grasping under the case near the rubber feet. Locate the unit on a sturdy table or bench top. Ambient temperatures should be inside the range of +50°F to +80°F (+10°C to +27°C).

### Electrical Requirements



**Line voltage may be easily accessible inside the pump/control box. Always unplug the unit prior to removing pump/control box cover.**

Refer to the serial number label on the rear of the unit to identify the specific electrical requirements of your unit.

Ensure the voltage of the power source meets the specified voltage,  $\pm 10\%$ .

The unit construction provides extra protection against the risk of electric shock by grounding appropriate metal parts. The extra protection may not function unless the power cord is connected to a properly grounded outlet. It is the user's responsibility to assure a proper ground connection is provided.



**For 220 - 240 volt units supplied without a line cord, use a harmonized (HAR) grounded 3-conductor cord, type H 0 5 V V - F , with conductors listed below. A suitable cord end is required for connecting to the equipment (see unit socket) and must terminate with an IEC approved plug for proper connection to power supply.**

**BOOST HEATER UNITS**

**Nominal 1.5 mm<sup>2</sup> cross section rated 16 Amps  
Unit Socket: IEC - 320 C19**

**NON-BOOST HEATER UNITS**

**Nominal 1.0 mm<sup>2</sup> cross section rated 10 Amps  
Unit Socket: IEC - 320 C13**

## Plumbing Requirements



**Ensure the unit is off before connecting tubing to the unit.**

**To prevent damage to the plumbing lines, always support the ¼" fittings while installing/removing the pumping caps and lines.**

### **Hose Connections**

The pump connections are located at the rear of the pump box and are labelled PUMP INLET and PUMP OUTLET. These connections are bent upward so the recirculating fluid will drain back into the reservoir when the hoses are disconnected. Both connections are capped with stainless steel serrated plugs.

The pump lines have ¼ inch male pipe threads for mating with standard plumbing fittings. For your convenience stainless steel adapters, ¼ inch female pipe thread to ⅜ inch O.D. serrated fitting, are provided. (To assure proper fit, they should be installed using Teflon® tape around the threads.)

Flexible tubing, if used, should be of heavy wall or reinforced construction. Make sure all tubing connections are securely clamped. Avoid running tubing near radiators, hot water pipes, etc. If substantial lengths of tubing are necessary, insulation may be required to prevent loss of cooling capacity.

Tubing and insulation are available from Thermo NESLAB. Contact our Sales Department for more information (see Preface, After-sale Support).

It is important to keep the distance between the unit and the external system as short as possible, and to use the largest diameter tubing practical. Tubing should be straight and without bends. If diameter reductions must be made, make them at the inlet and outlet of the external system, not at the unit.

If substantial lengths of cooling lines are required, they should be pre-filled with bath fluid before connecting them to the unit. This will ensure that an adequate amount of fluid will be in the bath once it is in operation.

### **Pumping**

The pump is designed to deliver a flow of 15 liters/minute (4 gallons minute) at 0 feet head. To prevent external circulation, the PUMP INLET and PUMP OUTLET lines on the rear of the unit are capped. The caps must be removed when external circulation is required.

To properly secure external hose connections to the unit, wrap Teflon® tape around the pipe line threads before installation. Once the hose connections are made, the hoses must be properly plumbed to an external system. *It is important the bath is not in operation until all plumbing is complete.*

If the bath is not used for external circulation, make sure the stainless steel caps are in place prior to operating the bath.

## Circulating to an open container

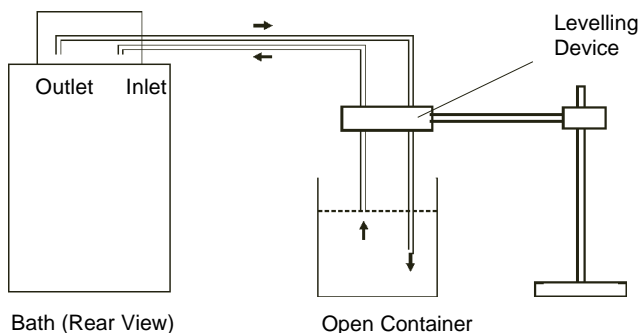

A stainless steel leveling device is available to aid circulation to an open vessel. Contact our Sales Department for more information (see Preface, After-sale Support).

Support the leveling device over the open container with a ringstand. Stagger the tubes in the leveling device so one tube is submerged in the vessel fluid, and the other tube is level with the fluid surface. Connect the deeper tube to the PUMP OUTLET and the shorter tube to the PUMP INLET.

Adjust the flow rate using the accessory flow control valve connected to the PUMP OUTLET, or by partially restricting the outlet tubing. When properly adjusted, the pump inlet will draw an occasional air bubble to prevent over flow, and the pump outlet will force fluid through the submerged tube to prevent aeration of the vessel.

To avoid siphoning the bath work area when the unit is shut off, lift the leveling device out of the vessel and above the level of the unit.

## Circulating through two closed loops

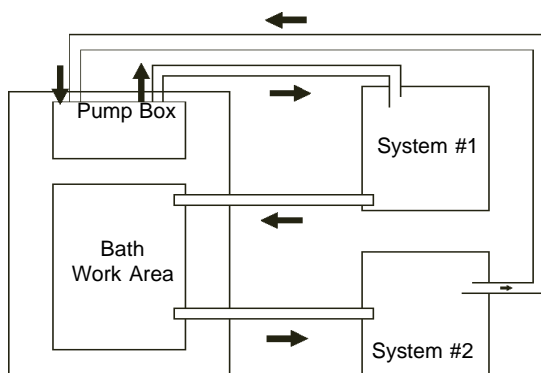

Bath (Top View)

The pump can be used to circulate through two closed loop systems. Connect the shortest practical length of flexible tubing from the PUMP OUTLET to the inlet of external system #1. Connect the outlet of system #1 directly into the bath work area. Connect tubing from the bath work area to the inlet of system #2. Connect the outlet of system #2 to the PUMP INLET.

## Tap Water Cooling Coils

The unit is equipped with a cooling coil located behind the stainless steel baffle in the bath. The bath can be cooled and temperature stability improved by circulating cold fluid through the coil. For best results, the fluid should be at least 5°C below the temperature setpoint. The required fluid flow rate depends on the type of fluid, the setpoint, and the desired stability.

The plumbing connections for the cooling coil are  $\frac{3}{8}$  inch OD stainless steel tubes located on the rear of the unit. These connections will accept  $\frac{3}{8}$  inch or  $\frac{5}{16}$  inch ID tubing. Tubing is available from Thermo NESLAB. Connect the COOLING COIL IN tube to the cold fluid source. Connect the COOLING COIL OUT tube to the cold fluid return (or drain if tap water is being used).

### Drain



**Ensure the temperature of the bath fluid is safe before draining the unit.**

The unit is equipped with a drain located at the back of the unit at the base of the bath. The drain has  $\frac{1}{4}$  inch male pipe threads and is capped with a stainless steel plug. To drain the reservoir simply remove the cap.

To assure proper fit when replacing the cap, be sure to line the threads with Teflon® tape.

### Fluids



**Never use flammable or corrosive fluids with this unit.**

Filtered tap water is the recommended fluid for operation from +8°C to +80°C.

Above +80°C, the user is responsible for fluids used.



**Never use pure ethylene glycol as a bath fluid. A minimum 80/20 mixture of Ethylene Glycol and tap water is allowed.**

### Filling Requirements

The bath work area has a high and low level marker to guide filling. The markers are 1 inch horizontal slits located in the center of the stainless steel baffle separating the work area and the pump assembly. The correct fluid level falls between these two markers. The heating coils will be exposed and may become damaged if the correct fluid level is not provided.

When pumping to an external system, keep extra fluid on hand to maintain the proper level in both the circulating lines and the external system.



**Never run the unit when the work area is empty. Avoid overfilling. Overfilling the bath may damage the insulation and affects stability.**

## Section IV Microprocessor Controllers

### Microprocessor Controller

#### Description

The microprocessor controller is designed as a separate component from the unit. The controller can be mounted directly on the pump box, or remotely from the bath. The controller provides proportional with integral and derivative (PID) control.

The controller has two sections. The upper section contains the LED indicators and the Main display which provide feedback to you about the controller and bath. The ten individual LED indicators provide output on selected parameters while the Main display will provide information on various unit conditions.<sup>1</sup> The lower section contains the keypad you use to input data to the controller.

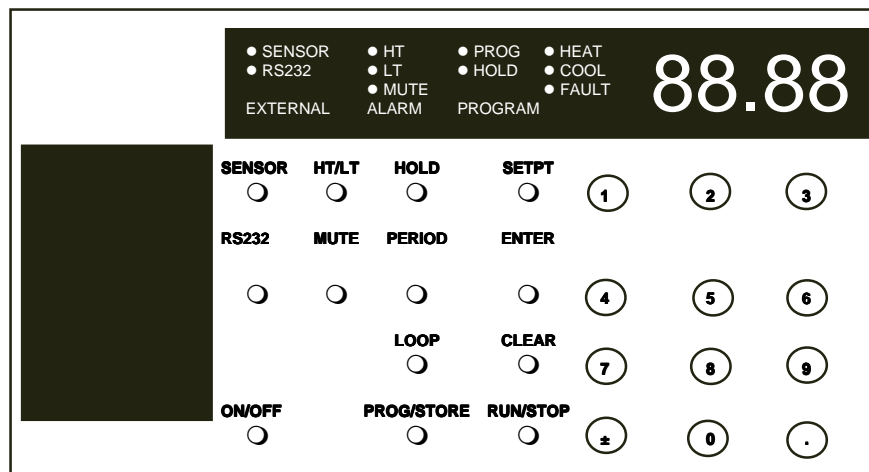

Microprocessor Temperature Controller (Front View)

#### Controller Mounting

The controller can be removed from the bath and placed in a remote location. Extension cables are available from Thermo NESLAB. Contact our Sales Department for more information.

#### Controller Connection

Microprocessor controllers are supplied with a cable needed to connect the controller to the pump box. Connect the cable to the 25-pin male connector on the control box and the female connector on the pump box. Once the connection is made, the unit is ready for operation.

**NOTE:** The MAIN POWER should be OFF before connecting/disconnecting cables from the control box.

1. The COOL LED is applicable only to refrigerated units.

## LED Indicators

The following table explains the controller LED indicators. The LEDs can be on, off or flashing.

LED	STATUS	INDICATION
SENSOR	OFF	All controller functions are operating from the unit's internal probe.
	ON	All controller functions are operating from remote sensor input.
	FLASHING	The Main display indicates the remote sensor temperature. The controller, however, still uses the internal probe to control the bath temperature.
RS232	OFF	Communication port disabled.
	ON	Communication port enabled.
	FLASHING	Awaiting next key press
LT	OFF	No alarm.
	ON	Main display indicates low limit setpoint.
	FLASHING	Low limit alarm condition.
HT	OFF	No alarm.
	ON	Main display indicates high limit setpoint.
	FLASHING	High limit alarm condition.
HOLD	OFF	Programming hold feature disabled.
	ON	Programming hold feature enabled.
PROG	OFF	No program running.
	ON	The program is suspended <sup>1</sup> .
	FLASHING	The program is running.
COOL <sup>2</sup>	OFF	Refrigeration is off.
	ON	Refrigeration is on.
HEAT	OFF	The heater is off.
	ON	The heater is on.
	FLASHING	The heater duty cycle.
MUTE	OFF	The alarm is enabled.
	ON	The alarm horn is disabled.
	FLASHING	The alarm horn has been disabled for any current condition. The alarm horn will automatically reset when the condition is cleared.
FAULT	OFF	No fault condition.
	ON	The high temperature/low level safety has activated.

1. The bath fluid will maintain the setpoint achieved at the time the program is suspended. No operator inputs are available to the controller while in a suspended condition.

2. The COOL LED is applicable only to refrigerated units.

## Start Up

Before starting the unit, check all electrical and plumbing connections and make sure the work area has been properly filled with bath fluid.

**NOTE:** The fluid level should be between the two lateral slots at the rear of the reservoir.

To power the controller on 115V units, place the MAIN POWER switch on the side of the unit to the ON position. This only supplies power to the controller. *The unit itself is not operating.* The Main display on the controller will display OFF.

220V units have a circuit breaker instead of a switch. The circuit breaker is labeled **I** (power on) and **O** (power off). Ensure the circuit breaker is in the **I** position.

Press the keypad ON/OFF button on the controller. The pump will start and the Main display will indicate the temperature of the fluid in the bath. The controller will respond to the current setpoint.

Pressing the keypad ON/OFF button again will disable control of the bath and shut down the pump. The Main display will indicate OFF. (When the controller is in the RS232 mode of operation, see page 13, the ON/OFF button is deactivated. Control of the bath can only be disabled via an RS232 input.)

## Temperature Adjustment

To display the temperature setpoint, press SETPT. The Main display will flash the current setpoint. Press ENTER to return the display to the bath's fluid temperature. To adjust the setpoint press SETPT and then press CLEAR, the display will go blank. Use the keypad to input the desired value. If the value is correct press ENTER. If the value is incorrect press CLEAR, the display will go blank. Use the keypad to correct the value and press ENTER.

### Low and High Temperature Limits

To display the temperature limits, press HT/LT. Either the HT or LT LED will illuminate and the Main display will flash the corresponding temperature limit. Press ENTER and then press HT/LT again to observe the other temperature limit. The corresponding LED on the controller will illuminate. Should either limit be exceeded an alarm will sound (if not muted) and the corresponding LED will flash.

To adjust either limit, press HT/LT and then press CLEAR, the display will go blank. Use the keypad to input the desired value. If the value is correct press ENTER. If the value is incorrect press CLEAR, the display will go blank. Use the keypad to correct the value and press ENTER. Use the LT or HT LED indicators to verify which temperature limit you are changing.

## Alarm/External Functions

### Mute Alarm

The alarm audio may be permanently silenced by pressing MUTE, and then immediately (within one second) pressing HOLD. The MUTE LED will now stay lit. To restore the audio, press MUTE and then immediately (within one second) press CLEAR. The MUTE LED will extinguish.

If desired, you may mute the audible portion of an alarm for an existing condition. Press MUTE on the temperature controller. The MUTE LED flashes to indicate a muted alarm horn. The MUTE button acts as a toggle switch to activate/deactivate the alarm horn. The appropriate HT or LT LED will continue to flash during the alarm condition. If the alarm is muted for an existing condition it will automatically reset once the temperature limit problem is corrected. The alarm will resound if a limit is exceeded another time unless MUTE is pressed again.

### Sensor

The controller has the capability to enable and/or monitor a remote bath's temperature sensor. (Remote sensor probes of various sizes are available from Thermo NESLAB. Contact our Sales Department for more information.)

Pressing SENSOR, when a remote sensor is properly connected to the controller's

9-pin SENSOR connector, will display the remote sensor's temperature on the Main display. The SENSOR LED will flash. *The controller and alarm, however, will continue to respond to the signals from the unit's internal probe.*

To completely transfer all display, control and alarm functions to the remote sensor, press SENSOR and then press ENTER. The SENSOR LED will stay lit. The controller will not respond to the signal from the unit's internal probe.

To disable the remote sensor press SENSOR and then press CLEAR. The SENSOR LED will extinguish. All display and alarm functions will again respond to the signal from the unit's internal probe.

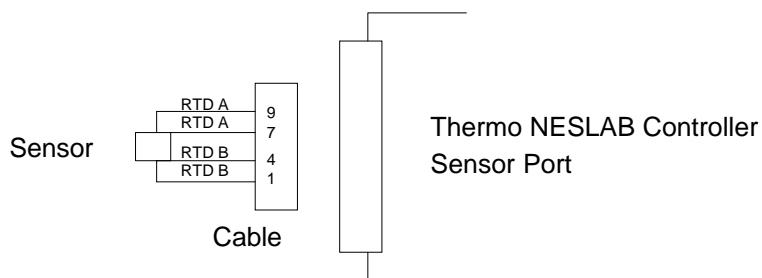

## RS232

The unit can be controlled through your computer's serial port by using a standard 9-pin RS232 connection on the rear of the temperature controller. For complete information see Appendix A.

## Program Functions

### Programming

The microprocessor controller can store up to 8 temperature programs, each one having up to 15 program steps (16 setpoints). You can select, enter or run one program at a time. The procedure for selecting a program is discussed in Program Control on page 15. The programs can cover the unit's full temperature operating range in 0.01°C increments. Step times can vary from 0.1 to 6,500 minutes in 0.1 minute increments. Each program can be set up to run as many as 9999 repetitions (LOOPS).

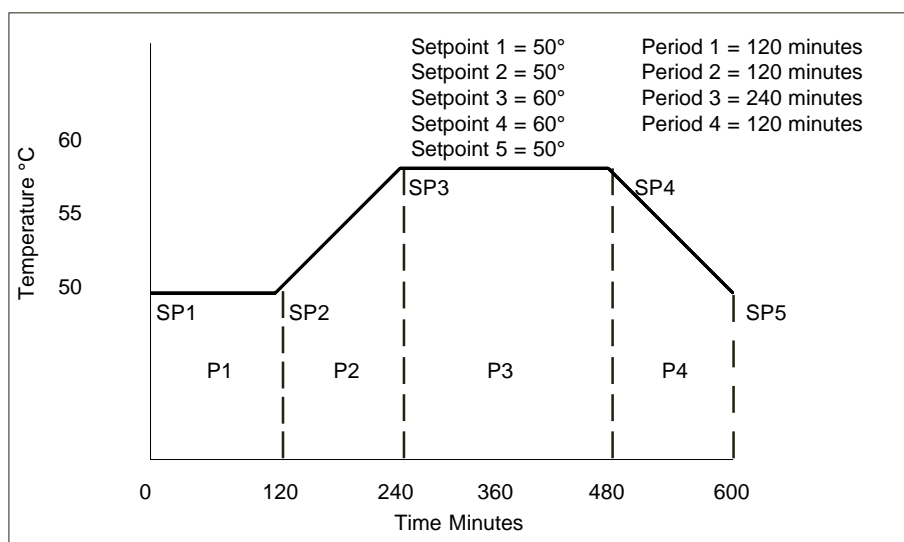

Typical Program

The controller can store all programs in its nonvolatile memory, see Program Control on page 16.

The programming process begins with program definition. Define your program as a series of setpoints with a known period of time interval between each of them. Each interval is one step of the program. Give careful attention to the first part of your program. What conditions must exist at the beginning of your process? For example, you may wish to program an initial period of constant temperature to allow for thermal stabilization.

When a program is started, it begins immediately at the initial program setpoint.

Consider the unit's limitations when designing programs. Temperature or time parameters which exceed the performance capabilities of the bath will result in unsatisfactory operation. It is possible to create a program calling for very rapid changes in temperature. Although the equipment may not be capable of producing such changes, it may be practical to program such steps as a way to cause the fastest *possible* temperature change.

### Loops

This option allows for automatic repetition(s) of a program. For example, set the number of loops to three. Once the program reaches the last setpoint, it will loop back to the first setpoint and run the program again. In this instance the program will loop back three times. The entire program will run a total of four times. The maximum number of loops is 9999.

### Hold

This option determines what will happen at the end of a program. In the hold mode of operation the setpoint will remain at the final temperature when the program is completed. Without hold the setpoint will return to the starting setpoint when the program is completed. The setpoint may change abruptly, but the fluid temperature will respond as quickly as the system's heating and cooling capacity allows.

The procedures for placing the controller in the hold mode is discussed in Program Control on page 16.

### Current Values

While a program is running, the program selected, current period, current setpoint, time remaining for the current step, or the current loop, may be viewed on the Main display. Momentarily depress the appropriate key listed below to view the desired parameter. After several seconds, the Main display will again indicate the temperature of the bath fluid.

<b>SETPT</b> .....	View Current Setpoint
<b>LOOP</b> .....	View Current Loop
<b>PERIOD</b> .....	Time Remaining in Current Period
<b>PERIOD PERIOD</b> .....	Current Period Number
+/- followed immediately by <b>PROG/STORE</b> —— Selected Program Number	

### Assured Soak

This option is used when you need to ensure the bath temperature will reach the next setpoint (regardless of time) before moving onto the next period.

This option is controlled by a DIP switch on the rear of the controller. Turn DIP switch number seven (7) to the ON position to enable this feature.

### Period Adjust

This option is used to skip the current period of a running program. See Table 13 on page 18 for the appropriate procedure. **NOTE:** If Assured Soak is activated, the bath *must* reach that setpoint before the program will continue.

## Program Control

The following tables show how to use the keypad and Main display to program the controller.

Use Table 1 to select one of the eight programs to be the current program for either entering or running.

<b>TABLE 1</b>		
Keypad input	Main Display	Comments
+/-	Current bath temperature	
-PROG/STORE <sup>1</sup>	<b>Pro</b> followed by the program number	Enter desired program number.
-ENTER	Current bath temperature	

1. PROG/STORE must be depressed immediately (within one second) after +/-.

Once Table 1 is complete, use Table 2 for entering and storing a two-setpoint program. You would follow this procedure for programming any number of setpoints (up to the 16 setpoint maximum).

<b>TABLE 2</b>		
Keypad input	Main Display	Comments
-PROG/STORE	-----	If YES appears you should clear the current program (see Table 10).
-SETPT	<b>SP-1</b>	Input setpoint.
-ENTER	Desired setpoint	
-PERIOD	<b>P-1</b>	Input time in minutes.
-ENTER	Desired time	
-SETPT	<b>SP-2</b>	Input setpoint.
-ENTER	Desired setpoint	
-LOOPS	<b>LOOPS</b>	Input number of loops
-ENTER	Desired number of loops	
-PROG/STORE	<b>FILE?</b>	
-ENTER	Current bath temperature	

Use Table 3 to abort programming at any time.

<b>TABLE 3</b>		
Keypad input	Main Display	Comments
-ENTER	-----	
-PROG/STORE	<b>FILE?</b>	
-CLEAR	Current bath temperature	

Use Table 4 to scroll through a two-setpoint stored program. You would use this procedure for scrolling any number of setpoints (up to the 16 setpoint maximum).

<b>TABLE 4</b>		
Keypad input	Main Display	Comments
-PROG/STORE	<b>YES</b>	
-ENTER	<b>SP-1</b> followed by actual value	
-ENTER	<b>SP-2</b> followed by actual value	
-ENTER	<b>P-1</b> followed by actual value	
-ENTER	<b>LOOPS</b> followed by actual value	
-ENTER	Current bath temperature	

Use Table 5 to abort scrolling through a program at any time.

<b>TABLE 5</b>		
Keypad input	Main Display	Comments
-PROG/STORE	<b>FILE?</b>	
-ENTER	Current bath temperature	

Once Tables 1 and 2 are complete, use Table 6 to run a stored program.

<b>TABLE 6</b>		
Keypad input	Main Display	Comments
-RUN/STOP	Current bath temperature	<b>PROG LED</b> will flash.

Use Table 7 to stop a running program.

<b>TABLE 7</b>		
Keypad input	Main Display	Comments
-RUN/STOP	Current bath temperature	<b>PROG LED</b> will stay on steady.
-CLEAR	Current bath temperature	<b>PROG LED</b> extinguishes.

Use Table 8 to temporarily suspend a running program.

<b>TABLE 8</b>		
Keypad input	Main Display	Comments
-RUN/STOP	Current bath temperature	<b>PROG LED</b> stays on steady.

Use Table 9 to resume a suspended program.

<b>TABLE 9</b>		
Keypad input	Main Display	Comments
-RUN/STOP	Current bath temperature	<b>PROG LED</b> flashes.

Use Table 10 to clear a stored program.

<b>TABLE 10</b>		
Keypad input	Main Display	Comments
-PROG/STORE	<b>YES</b>	
-PROG/STORE	<b>FILE?</b>	
-CLEAR	Current bath temperature	

Use Table 11 to add HOLD operation. (Hold must be established before running a program. The hold function is not part of the stored program.)

<b>TABLE 11</b>		
Keypad input	Main Display	Comments
-PROG/STORE	<b>YES</b>	
-HOLD	<b>YES</b>	<b>HOLD LED</b> stays on steady.
-PROG/STORE	<b>FILE?</b>	
-ENTER	Current bath temperature	

Use Table 12 to clear hold operation.

<b>TABLE 12</b>		
Keypad input	Main Display	Comments
-PROG/STORE	<b>YES</b>	
-HOLD	<b>YES</b>	<b>HOLD LED</b> extinguishes.
-PROG/STORE	<b>FILE?</b>	
-ENTER	Current bath temperature	

Use Table 13 to force a running program to skip ahead to the next period.

<b>TABLE 13</b>		
Keypad input	Main Display	Comments
+/-	Current bath temperature	
-PERIOD <sup>1</sup>	<b>P-Adj</b>	(Period adjust)

1. PERIOD must be depressed immediately (within one second) after +/-.

## Error Messages

The Main LED will indicate an error message for eight different conditions.

Error1 - Program incomplete or illogical. Re-enter the program.

Error2 - Period entered exceeds 6,500 minutes. Reenter a period.

Error3 - Entered value exceeds allowable limits. Reenter proper value.

Error4 - Loops entered greater than 9,999. Reenter loops

Error5 - Attempted to run a program without a program in memory.  
Build a program.

Error6 - No period or 0 entered entered for a program. Enter a period.

Error7 - With alarm - SENSOR depressed without a sensor properly connected to controller. Properly connect a sensor. (If sensor is properly connected the sensor may have failed.)  
Without alarm - Internal probe failure, unit will shut off.

Error8 - Internal nonvolatile memory has failed. Press ENTER for the controller to reinitialize nonvolatile memory to factory preset parameters. **NOTE:** This will erase any program and setpoints in nonvolatile memory. The unit will have to be recalibrated.

## Miscellaneous

### Additional Parameters

Two parameters can also be set while the controller is deactivated (Main display shows OFF). You can adjust the light intensity of the Main display and set the controller pushbuttons to "beep" or not when depressed.

To adjust the Main display intensity first press the "±" key on the controller keyboard. Repeatedly depress the "1" key to decrease intensity or the "3" key to increase. Each press changes the intensity an incremental amount. Once the desired intensity is displayed press ENTER.

To silence the "beep" first press the "." key. Press "0" to turn the beep off or press "1" to turn it on. Next, press ENTER.

### DIP Switches

Three DIP switches on the rear of the controller are operational. Switch #1 controls the temperature scale. OFF (up position) displays the temperature in °C, ON (down position) displays the temperature in °F.

Switch #6 sets the display update rate the controller uses to display temperature. This will determine how sensitive the display will be to temperature fluctuations. OFF (up position) sets a fast rate, ON (down position) sets a slow rate. (OFF causes more fluctuations than ON.)

Switch #7 controls the assured soak option for programs. ON enables assured soak.

## **PID Control**

PID controllers are best suited for systems that may experience changing heat loads. Proportional control is combined with Integral and Derivative adjustments which allow the controller to automatically compensate for any changes from the setpoint. You may have to experiment with the PID settings to find out which are most suitable to your application.

To change or view any of the PID settings the controller must be operating.

To change or view the proportional band, press "1" and immediately, within one second, press ENTER. The "percent of span" value will flash on the Main display. Press ENTER to accept the value. To change the value press CLEAR and then enter the desired value. Press ENTER to exit this mode.

To change or view the Integral, press "2" and immediately, within one second, press ENTER. The "repeats per minute" value will flash on the Main display. Press ENTER to accept the value. To change the value press CLEAR and then enter the desired value. Press ENTER to exit this mode.

To change or view the Derivative, press "3" and immediately, within one second, press ENTER. The "minutes" value will flash on the screen. Press ENTER to accept the value. To change the value press CLEAR and then enter the desired value. Press ENTER to exit this mode.

## **Restoring Factory Preset Values**

To restore the factory preset values hold the "0" button on the keypad and turn the Main Power switch on the side of the unit to the ON position. Release the "0" button and the Main display will indicate OFF. The following preset values will be installed:

P = 0.6%  
I = 0.25 repeats per minute  
D = 0.05 minutes

In addition, the following values will be preset

BAUD Rate = 9600  
Stop bits = 1  
Data Bits = 8  
Parity = none

## Calibration

The microprocessor controller has three different modes of calibration: Self-Cal, Two-point, and One-point. The controller is shipped from the factory with a Two-point calibration so no additional controller calibration may be required. Both the internal probe and the remote sensor input must be independently calibrated. Different calibration modes for each probe can be used if desired. The remote sensor input has been Self-Calibrated at the factory.

Self-Cal is used to initialize the analog-to-digital (A/D) converter input channel before performing the other types of calibrations. This mode removes all previous calibrations and brings the measurement error to less than 2°C. If this is the required accuracy, then no additional calibration is needed.

Two-point calibration is used to negate A/D and probe errors over the full span of the controller. This type of calibration is performed when high accuracy is desired.

One-point calibration (offset) is used to make the controller very accurate at one specific operating temperature.

One-point Calibration can be performed after a Two-point calibration as many times as desired. Each One-point calibration adds a different offset to the original Two-point calibration data (if one was already performed).

### Calibration Procedures

**Note:** The controller should be powered at least 15 minutes before calibration to assure the electronic circuits are at operating temperature. To perform One and Two-point calibrations on the remote sensor input the unit must be in the remote sensor mode. Messages will end with CAL 1 for internal probe calibrations and CAL 2 for remote sensor calibrations.

**Self-Cal:** The controller must be deactivated (displaying OFF) to access this mode. Press SETPT followed by ENTER to Self-Cal the internal probe input. The message "S-CAL 1" will be followed by "done". To Self-CAL the sensor input press SENSOR followed by ENTER. The message "S-CAL 2" followed by "done" will be displayed.

**Two-point:** For high accuracy measurements the controller input can be calibrated at two points. These two points (one high, one low) should be as far apart as practical for good performance.



**Do not pick points that are outside the safe operating limits of the fluid in your application. For example with a water bath, 5°C and 90°C would be typical calibration points.**

Before a Two-point cal, Self-cal must be performed on the desired sensor input.

With the controller on and measuring from the internal or remote probe, depending on which sensor is being calibrated, set the controller setpoint to the desired high cal temperature. When the bath reaches the setpoint and stabilizes, measure the actual bath temperature with an external calibrated thermometer. Press in quick succession “2” “.” “ENTER”. The message H-CAL # will appear followed by the flashing setpoint. Now enter in the actual bath temperature as measured by the calibrated thermometer and press ENTER. The Main display will indicate the temperature of the bath fluid (the calibrated temperature will not appear until the next step is complete).

Next set the controller setpoint to the desired low cal temperature. When the bath reaches this setpoint and stabilizes, measure the actual bath temperature with an external calibrated thermometer. Press in quick succession “2” “.” “ENTER”. The message L-CAL # will appear followed by the flashing setpoint. Now enter in the actual bath temperature as measured by the calibrated thermometer and press ENTER. The Main display will now indicate the calibrated temperature of the fluid in the bath.

**One-point:** Before a One-point cal, Self-cal or Two-point cal must be performed on the desired sensor.

With the controller on, and measuring from the internal or remote probe, depending on which sensor is being calibrated, set the controller setpoint to the desired temperature. When the bath reaches this setpoint and stabilizes, measure the actual bath temperature with an external calibrated thermometer. Press in quick succession “1” “.” “ENTER”. The message 1-CAL # will appear followed by the flashing setpoint. Now enter in the actual bath temperature as measured by the calibrated thermometer and press ENTER. The display will now show the calibrated temperature and all temperatures will have this offset added to them.

**Calibration clear:** At any point the calibration data from a One or Two-point cal can be erased by quickly pressing “2” “.” “CLEAR”. This procedure clears the calibration data only for the selected probe.

## High Temperature/ Low Liquid Level Safety

To protect your application, the adjustable High Temperature/Low Liquid Level Safety (HIGH TEMP/LOW LEVEL) ensures the heater will not exceed temperatures which can cause serious damage to your unit. A single temperature sensor, located on the heater coils in the bath, monitors both conditions. A High Temperature/Low Liquid Level fault occurs when the temperature of the sensor exceeds the set temperature limit.

In the event of a fault, the unit will shut down. The cause of the fault must be identified and corrected before the unit can be restarted.

The safety on single heater systems is not preset and must be adjusted during initial installation.

Units with a boost heater have an additional nonadjustable safety located behind the main safety. It has a red reset button but no adjustment knob.

To set the safety, locate the HIGH TEMP/LOW LEVEL SAFETY adjustment dial on the right side of the pump box. Turn the dial fully clockwise and press the red RESET switch. The RESET switch is located NEXT TO the adjustment dial. **NOTE:** For units without a reset switch turn the power switch off and then back on.

Start the unit. Adjust the setpoint for a few degrees higher than the highest desired fluid temperature and allow the bath to stabilize at the temperature setpoint. Turn the HIGH TEMP/LOW LEVEL SAFETY dial counter-clockwise until you hear a click and the unit shuts down. The red FAULT LED on the temperature controller will light to indicate a fault has occurred.

**NOTE:** The minimum high temperature safety setting is 50°C. For units without a reset switch the temperature range is 0°C to 180°C.

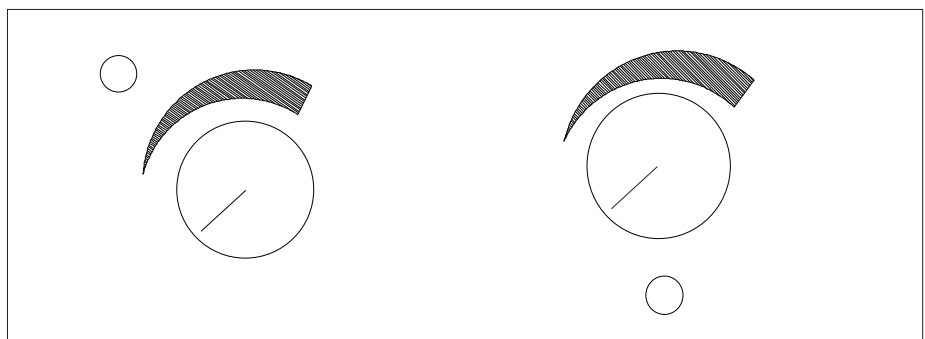

High Temperature/Low Liquid Level Safety  
(Some units do not have a reset switch.)

## Section V Maintenance



**To avoid electrical shock, disconnect the mains cord prior to removing any access panels or covers.**

### Service Contracts

Thermo NESLAB offers on-site Service Contracts that are designed to provide extended life and minimal down-time for your unit. For more information, contact our Service Department (see Preface, After-sale Support).

### Reservoir Cleaning

Routine cleaning can be achieved by simply sponging down the seamless stainless steel tank with tap water. (Dish washing detergent may be used but the tank must be thoroughly rinsed.)

To gain access to the entire reservoir the pump box and reservoir cover should be removed.

Remove the line cord from the rear of the unit.

Remove the four screws securing the reservoir's cover.

Carefully raise the controller and cover assembly to remove it from unit.

Place the cover on its side.

### Algae

To restrict the growth of algae in the bath, we recommend the bath cover be kept in place and that all circulation lines be opaque. This will eliminate the entrance of light required for the growth of most common algae.

Thermo NESLAB recommends the use of Chloramine-T, 1 gram per 3.8 liters.

## Section VI Troubleshooting

### Checklist

#### Unit will not start

Make sure the voltage of the power source meets the specified voltage,  $\pm 10\%$ . Refer to the serial number label on the rear of the unit to identify the specific electrical requirements of your unit.

Check the High Temperature/Low Liquid Level Safety. If the FAULT light is on, make sure the fluid level in the bath is between the marks in the baffle and the HIGH TEMP/LOW LEVEL SAFETY setting is greater than the fluid temperature. Push the RESET switch(es), or, for units without a reset switch, turn the power switch off and then back on and attempt to restart.

#### No external circulation

Make sure the stainless steel plugs on the PUMP INLET and PUMP OUTLET have been removed.

Check for obstructions, kinks, or leaks in the circulation tubing.

Circulation will cease when the pump head has been exceeded.

#### No communication between bath's microprocessor and your computer

Ensure the bath's microprocessor parameters (baud rate, parity etc.) match your computer requirements.

Ensure the RS-232 light is on steady. **NOTE:** You cannot input data from the keypad when the RS-232 mode is enabled.

Check the cable. The microprocessor reads data on pin 2 and transmit data on pin 3. Ensure the cable is correctly connected. Computer 25-pin and 9-pin communication ports usually have different conventions.

Ensure the only pins connected to the microprocessor are 2, 3 and 5. All other pins must *not* be connected.

#### Keypad locked up

**NOTE:** When communication is enabled, or a program is running, data entry and many keypad functions are disabled. This is normal operation.

If necessary, remove computer cable. Turn off the bath using the main power switch on the side of the unit. While holding the "0" button on the keypad, turn the unit back on. The Main Display will read OFF.

This will also restore the factory preset PID values and also reset the communication parameters and buffer. See Restoring Factory Preset Values on page 20.

## **Service Assistance and Technical Support**

If, after following these troubleshooting steps, your unit fails to operate properly, contact our Customer Service Department for assistance (see Preface, After-sale Support). Before calling, please obtain the following information:

*Part number*

*Serial number*

*Voltage of unit*

*Voltage of power source*

In addition to arranging warranty service, our Service Department can provide you with a wiring diagram and a complete list of spare parts for your unit. Before calling, please obtain the following information:

*Part number*

*Serial number*

## Appendix A RS-232

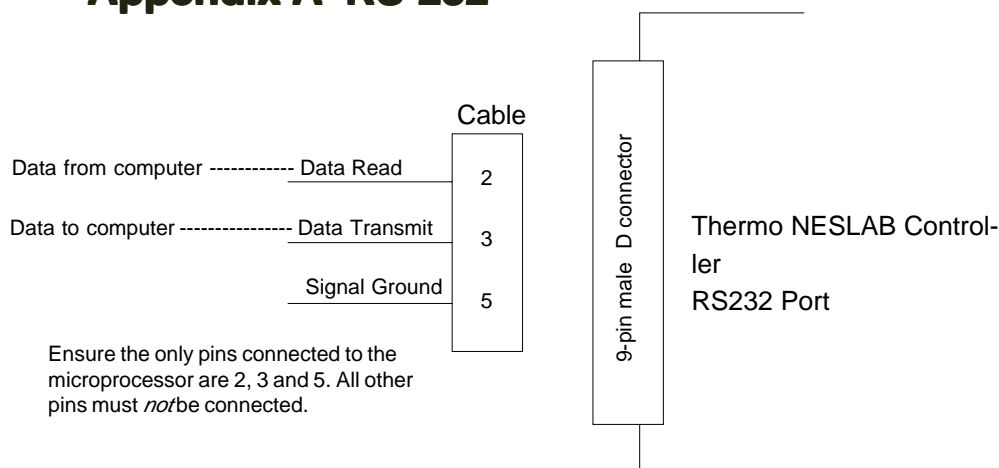

The unit can be controlled through your computer's serial port by using a standard 9-pin RS232 connection on the rear of the temperature controller. Data transmit of the serial port connects to data read (pin 2) of the bath. Data read of the serial port connects to the data transmit (pin 3) of the bath.

**NOTE:** Do not use a cable that connects to the unused pins on the bath communications port. This may cause a communication fault. Communication cables are available from Thermo NESLAB. Contact our sales department for additional information.

With a cable properly connected to the controller press RS232, the RS232 LED will start to flash. Press ENTER while the LED is flashing and the RS232 LED will come on steady indicating your computer's serial port can control the unit's operation.

In this mode of operation you cannot manually input data with the keypad. You can, however, observe the setpoint and/or alarm temperature limits by pressing the appropriate button on the controller. Your computer can be used to operate all modes of operation.

**NOTE:** When serial communication is enabled, and a temperature program is running, no keypad operations are allowed.

### Communication Commands

All commands must be entered in the exact format shown in the following four tables. Do not send a [LF] (line feed) after the [CR]. Ensure the specified letter case is used. The tables on the next few pages show all commands available, their format and responses. Controller responses are either the requested data, an exclamation point (!) if the command was properly executed, or a question mark (?) if the controller could not execute the command. A question mark response indicates either an improper command format or an attempt to enter settings that are outside the allowable range. The controller response *must* be received before sending the next command.

**NOTE:** All responses from the bath are terminated with a single [CR] only. Wait for your computer to respond before sending the next command.

**TABLE 1 GENERAL COMMANDS**

Command Echo	SEi[CR]
Echo: i = 1, No echo: i = 0 (control returns commands)	
Set Setpoint	SSxxx.xx[CR]
-30.00 to +150.00°C or -22.00 to +300.00°F	
Read Setpoint	RS[CR]
Read Main Probe Temperature	RT[CR]
Read Remote Probe Temperature	RR[CR]
Turn Control On or Off	SOi[CR]
On: i = 1, Off: i = 0	
Set Power Status Flag	SWi[CR]
Set: i = 1, Reset i = 0 (reset when controller power is lost)	
Read Power Status Flag	RW[CR]
Read F or C Units	RU[CR]

**TABLE 2 ALARM COMMANDS**

Set High Alarm Limit	SHxxx.xx[CR]
Same range as setpoint	
Read High Alarm Limit	RH[CR]
Set Low Alarm Limit	SLxxx.xx[CR]
Same range as setpoint	
Read Low Alarm Limit	RL[CR]
Read Alarm Status	RF[CR]
Returns: 0 = no alarm, 1 = alarm	

**TABLE 3 CONTROL COMMANDS**

Set Proportional Bandwidth	SPxx.xx[CR]
0.10 to 10.00 % of full scale	
Read Proportional Bandwidth	RP[CR]
Set Integral Compensation	SIxx.xx[CR]
0.00 to 10.00 repeats/minute	
Read Integral Compensation	RI[CR]
Set Derivative Compensation	SDx.xx[CR]
0.00 to 1.00 minutes	
Read Derivative Compensation	Rd[CR]
Main/Remote Probe Selection	Sri[CR]
Main: i = 0, Remote: i = 1	
Boost Heater Inhibit	SBi[CR]
Inhibit: i = 0, Enable: i = 1	

**TABLE 4 PROGRAMMING COMMANDS**

Set Step Setpoint n = step number	SYn,xxx.xx<[CR]
Read Step Setpoint	RYn[CR]
Set Step Period n = step number	SXn,xxx.xx[CR]
Read Step Period	RXn[CR]
Read Number of Steps	Rs[CR]
Set Number of Loops 0 to 9999 additional loops after first program execution	SKxxxx[CR]
Read Number of Loops	RK[CR]
Set Hold Status Hold: i = 1, No hold: i = 0	SZi[CR]
Pause/Resume Program Resume: i = 1, Pause: i = 0	SGi[CR]
End Program	SR[CR]
Read Elapsed Step Time	RE[CR]
Select Program Number	SVx[CR]
Read Selected Program Number	RV[CR]
Read Current Period	RC[CR]
Skip Ahead One Period	SJ[CR]

To set the communications data format the controller must be deactivated (Main display indicates OFF). Press the RS232 button. The word "Baud" will momentarily appear followed by the current baud rate (9600, 4800, 1200, 600 or 300). Use the keypad to enter the desired change, if any. Press ENTER and "db" will momentarily appear followed by the current number of data bits setting. Again, use the keypad to enter any desired change (7 or 8) and then press ENTER. "Sb" will momentarily appear followed by the current number of stop bits (1 or 2). Change, if needed, and press ENTER and "PAr" will momentarily appear followed by the current parity control setting (0 = none, 1 = odd, 2 = even). Change, if needed, and press ENTER.

To manually exit this mode of operation press RS232. The RS232 LED will start to flash. Press the CLEAR button and the RS232 LED will extinguish.

## Communication Command Protocol

The following table lists the communication command protocol for programming the controller via a computer. Use the Ctrl - C key combination to clear the controller receiving buffer if an erroneous character is detected.

<b>FUNCTION</b>	<b>SYNTAX<sup>1</sup></b>	<b>RETURN MESSAGE<sup>2</sup></b>
SET SETPOINT	SSxxx.xx[CR]	![CR]
SET LOW LIMIT	SLxxx.xx[CR]	![CR]
SET HIGH LIMIT	SHxxx.xx[CR]	![CR]
SET PROPORTIONAL BAND <sup>3</sup>	SPxx.xx[CR]	![CR]
SET INTEGRAL <sup>4</sup>	SIxx.xx[CR]	![CR]
SET DERIVATIVE <sup>5</sup>	SDx.xx or Sdx.xx[CR]	![CR]
BOOST HEATER INHIBIT	SBi[CR]	![CR]
SET POWER STATUS FLAG	SWi[CR]	![CR]
SET ON/OFF	SOi[CR]	![CR]
SELECT PROGRAM NUMBER	SVx[CR]	![CR]
SET STEP SETPOINT	SYn,xxx.xx[CR]	![CR]
SET STEP PERIOD	SXn,xxx.x[CR]	![CR]
SET NUMBER OF PERIODS	Ssn[CR]	![CR]
SET NUMBER OF LOOPS	SKxxx[CR]	![CR]
SET HOLD STATUS	SZi[CR]	![CR]
END PROGRAM	SR[CR]	![CR]
ECHO CONTROL <sup>6</sup>	SEi[CR]	![CR]
REMOTE SENSOR CONTROL	Sri[CR]	![CR]
SUSPEND/RESUME PROGRAM	SGi[CR]	![CR]
SKIP AHEAD ONE PERIOD	SJ[CR]	![CR]
READ SETPOINT	RS[CR]	xxx.xx[CR]
READ TEMPERATURE	RT[CR]	xxx.xx[CR]
READ ALARM STATUS	RF[CR]	![CR]
READ REMOTE TEMPERATURE	RR[CR]	xxx.xx[CR]
READ UNITS	RU[CR]	C[CR] or F[CR]
READ CURRENT PERIOD	RC[CR]	xx[CR]
READ ELAPSED TIME	RE[CR]	xxx.x[CR]
READ LOW LIMIT	RL[CR]	xxx.xx[CR]
READ HIGH LIMIT	RH[CR]	xxx.xx[CR]
READ PROPORTIONAL BAND	RP[CR]	xx.xx[CR]
READ INTEGRAL	RI[CR]	xx.xx[CR]
READ DERIVATIVE	Rd[CR]	x.xx[CR]
READ PROGRAM NUMBER	RV[CR]	x[CR]
READ STEP SETPOINT	RYn[CR]	xxx.xx[CR]
READ STEP PERIOD	RXn[CR]	xxx.x[CR]
READ NUMBER OF STEPS	Rs[CR]	x[CR]
READ NUMBER OF LOOPS	RK[CR]	xxxx[CR]
READ POWER STATUS	RW[CR]	x[CR]

1. x = ASCII digit, i = 0 (OFF or STOP) i = 1 (ON or GO), n = step number.

2. Ensure the return message is correct. If not, resend or troubleshoot communication lines.

3. Factory preset at 0.6%.

4. Factory preset at 0.25 repeats per minute.

5. Factory preset at 0.05 minutes.

6. Allows computer to compare send signal to receive signal.

## Remote Programming

The bath can be programmed and controlled by a remote computer. Enter step setpoints using the SYn command, time periods using the SXn command, number of loops using the SKxxx command and number of periods in the program using the Ssn command. Start the program using SG1 and suspend the program using SG0. When the program is finished it will stop automatically. If needed, SR will end the program at any time. Here is a four setpoint, two loop example:

SV1[CR]	Select program number one
SY1,25.00[CR]	First setpoint = 25.00 degrees
SX1,20.0[CR]	First period = 20.0 minutes
SY2,40.00[CR]	Second setpoint = 40.00 degrees
SX2,60.0[CR]	Second period = 60.0 minutes
SY3,40.00[CR]	Third setpoint = 40.00 degrees
SX3,45.0[CR]	Third period = 45.0 minutes
SY4,25.00[CR]	Fourth setpoint = 25.00 degrees
Ss3[CR]	Program has three periods
SK2[CR]	Execute the program three times total
SG1[CR]	Begin executing program
SG0[CR]	Temporarily suspend the program
SR[CR]	Stop the program before it is finished

## WARRANTY

Thermo NESLAB Instruments, Inc. warrants for 12 months from date of shipment any Thermo NESLAB unit according to the following terms.

Any part of the unit manufactured or supplied by Thermo NESLAB and found in the reasonable judgment of Thermo NESLAB to be defective in material or workmanship will be repaired at an authorized Thermo NESLAB Repair Depot without charge for parts or labor. The unit, including any defective part must be returned to an authorized Thermo NESLAB Repair Depot within the warranty period. The expense of returning the unit to the authorized Thermo NESLAB Repair Depot for warranty service will be paid for by the buyer. NESLAB's responsibility in respect to warranty claims is limited to performing the required repairs or replacements, and no claim of breach of warranty shall be cause for cancellation or rescission of the contract of sales of any unit.

With respect to units that qualify for field service repairs, Thermo NESLAB's responsibility is limited to the component parts necessary for the repair and the labor that is required on site to perform the repair. Any travel labor or mileage charges are the financial responsibility of the buyer.

The buyer shall be responsible for any evaluation or warranty service call (including labor charges) if no defects are found with the Thermo NESLAB product.

This warranty does not cover any unit that has been subject to misuse, neglect, or accident. This warranty does not apply to any damage to the unit that is the result of improper installation or maintenance, or to any unit that has been operated or maintained in any way contrary to the operating or maintenance instructions specified in Thermo NESLAB's Instruction and Operation Manual. This warranty does not cover any unit that has been altered or modified so as to change its intended use.

In addition, this warranty does not extend to repairs made by the use of parts, accessories, or fluids which are either incompatible with the unit or adversely affect its operation, performance, or durability.

Thermo NESLAB reserves the right to change or improve the design of any unit without assuming any obligation to modify any unit previously manufactured.

THE FOREGOING EXPRESS WARRANTY IS IN LIEU OF ALL OTHER WARRANTIES, EXPRESSED OR IMPLIED, INCLUDING BUT NOT LIMITED TO WARRANTIES OR MERCHANTABILITY AND FITNESS FOR A PARTICULAR PURPOSE.

NESLAB'S OBLIGATION UNDER THIS WARRANTY IS STRICTLY AND EXCLUSIVELY LIMITED TO THE REPAIR OR REPLACEMENT OF DEFECTIVE COMPONENT PARTS AND Thermo NESLAB DOES NOT ASSUME OR AUTHORIZE ANYONE TO ASSUME FOR IT ANY OTHER OBLIGATION.

Thermo NESLAB ASSUMES NO RESPONSIBILITY FOR INCIDENTAL, CONSEQUENTIAL, OR OTHER DAMAGES INCLUDING, BUT NOT LIMITED TO LOSS OR DAMAGE TO PROPERTY, LOSS OF PROFITS OR REVENUE, LOSS OF THE UNIT, LOSS OF TIME, OR INCONVENIENCE.

This warranty applies to units sold in the United States. Any units sold elsewhere are warranted by the affiliated marketing company of Thermo NESLAB Instruments, Inc. This warranty and all matters arising pursuant to it shall be governed by the law of the State of New Hampshire, United States. All legal actions brought in relation hereto shall be filed in the appropriate state or federal courts in New Hampshire, unless waived by Thermo NESLAB.